



Artiglio Master 28

Cod. 4-137578 - 09/2019

Italiano	Manuale d'uso	3
English	Operator's manual	85
Français	Manuel d'utilisation	167
Deutsch	Betriebsanleitung	249
Español	Manual de uso	331

TRANSLATION FROM THE ORIGINAL LANGUAGE
Copyrighted material. All rights reserved.
The included information may be changed without notice.

Thank you for selecting our tyre changer

CORGHI

Dear Customer,

Thank you for purchasing a Corghi tyre changer.

Your Tyre Changer has been designed to provide years of safe and reliable service, as long as it is used and maintained in accordance with the instructions provided in this manual. Anyone using and/or carrying out maintenance on this Tyre Changer must read, understand and follow all warnings and instructions provided in this manual, and be properly trained. This Instruction Manual should be considered an integral part of your Tyre Changer and should remain with the Tyre Changer. However, nothing in this manual, and none of the devices installed on the Tyre Changer, can replace proper training, correct operation, careful evaluation of procedures and safe working practices.

Always be sure that your Tyre Changer is in excellent working order. In case any malfunction or possible dangerous situation are observed, immediately shut down the Tyre Changer and resolve the situation before you proceed.

For any question related to the correct tyre changer use or maintenance, contact your local official Corghi dealer.

Sincerely,
Corghi

USER INFORMATION

Name

User _____

Address

User _____

Model

number _____

Serial

number _____

Date of

purchase _____

Date of

installation _____

Service

and spare parts manager _____

Phone

number _____

Sales

manager _____

Phone

number _____



TRAINING CHECK

	Qualified	Rejected
<u>Safety measures</u>		
Warning and caution labels	<input type="checkbox"/>	<input type="checkbox"/>
High risk areas and other potential hazards	<input type="checkbox"/>	<input type="checkbox"/>
Operative safety procedures	<input type="checkbox"/>	<input type="checkbox"/>
<u>Checking maintenance and performance</u>		
Head mounting inspection	<input type="checkbox"/>	<input type="checkbox"/>
Adjustment and lubrication	<input type="checkbox"/>	<input type="checkbox"/>
Maintenance and instruction messages	<input type="checkbox"/>	<input type="checkbox"/>
<u>Clamping</u>		
Steel/alloy rims	<input type="checkbox"/>	<input type="checkbox"/>
Reverse rims	<input type="checkbox"/>	<input type="checkbox"/>
Closed rims	<input type="checkbox"/>	<input type="checkbox"/>
<u>Bead breaking</u>		
Standard wheels	<input type="checkbox"/>	<input type="checkbox"/>
Low profile wheels	<input type="checkbox"/>	<input type="checkbox"/>
<u>Demounting</u>		
Bead lubrication when removing the low profile tyres	<input type="checkbox"/>	<input type="checkbox"/>
Reverse rims	<input type="checkbox"/>	<input type="checkbox"/>
<u>Mounting</u>		
Standard wheels	<input type="checkbox"/>	<input type="checkbox"/>
Mounting of stiff, low profile tyres	<input type="checkbox"/>	<input type="checkbox"/>
Wheels with reverse rim	<input type="checkbox"/>	<input type="checkbox"/>
Bead lubrication for proper mounting	<input type="checkbox"/>	<input type="checkbox"/>
WDK procedure	<input type="checkbox"/>	<input type="checkbox"/>
<u>Accessories</u>		
Instructions for correct use of the accessories	<input type="checkbox"/>	<input type="checkbox"/>
Inflatron user instructions (optional)	<input type="checkbox"/>	<input type="checkbox"/>
<u>Inflating procedure</u>		
Safety measures	<input type="checkbox"/>	<input type="checkbox"/>
Lubrication and removal of the valve insert	<input type="checkbox"/>	<input type="checkbox"/>
Tubeless tyre inflation	<input type="checkbox"/>	<input type="checkbox"/>

Personnel and training dates

EN

Contents

1. COMMISSIONING	90
1.1 INTRODUCTION	90
1.1.A. PURPOSE OF THE MANUAL	90
1.2 FOR YOUR SAFETY	90
1.2.A. GENERAL WARNINGS AND INSTRUCTIONS	91
1.2.B. LABELS PLACEMENT	94
1.2.C. ELECTRICAL AND PNEUMATIC CONNECTIONS	99
1.2.D TECHNICAL DATA	100
1.2.E. AIR PRESSURE	101
1.3. ADDITIONAL RIM/TYRE INFORMATION	101
1.4. INTENDED MACHINE USE	101
1.5. PERSONNEL TRAINING	102
1.6. PRELIMINARY CHECKS	102
1.7. DURING USE.....	102
2. TRANSPORT, STORAGE AND HANDLING	103
2.1. UNPACKING	103
3. ASSEMBLY/HANDLING	104
3.1. LIFTING/HANDLING	105
3.2. INSTALLATION	105
4. INSTALLATION AREA	108
5. ARTIGLIO MASTER 28 DESCRIPTION	109
5.1. OPERATOR POSITION.....	109
5.2. OVERALL DIMENSIONS.....	110
5.3. EQUIPMENT COMPONENTS (MAIN WORKING OPERATING ELEMENTS OF THE MACHINE)	110
5.4. CONTROLS.....	112
5.4.A. ON/OFF SWITCH	112
5.4.B. CONTROL CONSOLE.....	113
5.4.C. PEDAL UNIT	114
PEDAL UNIT (“AUTOMATIC” VERSION)	114
5.4.D. WHEEL LIFTER PEDAL UNIT (FIG. 23) (OPTIONAL)	115
5.4.E. PRESSURE GAUGE WITH DEFLATION PUSH-BUTTON (FIG. 24)	115
6. BASIC PROCEDURES - USE	115
6.1. PRELIMINARY CHECKS	116
6.2. TURNING THE MACHINE ON	116
6.3. DECIDING FROM WHICH SIDE OF THE WHEEL THE TYRE MUST BE REMOVED	117
6.4. WHEEL LOADING	118
6.5. CLAMPING THE WHEEL ON THE TURNTABLE	119
6.5a. CLAMPING THE WHEEL ON	
THE TURNTABLE	120

6.6. CONFIGURATION OF WHEEL DATA	121
6.7. TYRE DEFLATION	122
6.8. BEAD BREAKING	122
6.9. DEMOUNTING	125
6.10. MOUNTING	127
6.11. APPROVED UHP AND RUN FLAT TYRE DEMOUNTING AND MOUNTING PROCEDURE	130
6.12. TYRE INFLATION	131
6.12.A. SAFETY REGULATIONS	131
6.12.B. TYRE INFLATION	132
6.12.C. SPECIAL PROCEDURE (TI VERSION)	132
6.13 UNCLAMPING AND UNLOADING THE WHEEL	136
6.13.A. WHEEL UNCLAMPING	136
WHEEL UNCLAMPING ("AUTOMATIC" VERSION)	136
6.13.B WHEEL UNLOADING	137
7. TROUBLESHOOTING	137
7.1 LIST OF DISPLAY SIGNALS	137
8. MAINTENANCE	138
Scheduled maintenance:	139
9. INFORMATION ABOUT DEMOLITION	141
10. ENVIRONMENTAL INFORMATION	141
11. INFORMATION AND WARNINGS ABOUT OIL	142
12. INFORMATION AND WARNINGS ABOUT TYRE LUBRICATING FLUID ..	143
13. FIREFIGHTING EQUIPMENT TO BE USED	143
14. GLOSSARY	144
TABLE FOR USING CENTRING AND CLAMPING ACCESSORIES ACCORDING TO RIM TYPE	148
WIRING DIAGRAM	156
PNEUMATIC DIAGRAM	163

1. COMMISSIONING

1.1 INTRODUCTION

1.1.a. PURPOSE OF THE MANUAL

The purpose of this manual is to provide the instructions necessary for optimum operation, use and maintenance of your machine. If you sell this machine, please deliver this manual to the new owner. Furthermore, ask the new owner to fill out the ownership transfer module attached to the previous page in the manual and send it to Corghi, so that Corghi will be able to provide the customer with all necessary safety information. Alternately, the new owner can send an email to service@corghi.com.

This manual presumes that the technicians have a thorough understanding of rims and tyre identification and maintenance. He/she must also have a thorough knowledge of the operation and safety features of all associated tools (such as the rack, lift, or floor jack) being utilized, and have the proper hand and power tools necessary to work in a safe manner.

The first section explains the basic information regarding the safe operation of the Master 28 tyre changer family. The following sections contain detailed information regarding the equipment, procedures and maintenance. Italics are used to refer to specific parts of this manual that offer additional information or clarifications.

These references must be read in order to obtain information additional to the instructions provided.

The owner of the tyre changer is the only person responsible for the observance of the safety procedures and the organisation of technical training. The tyre changer must only be used by qualified, specifically trained technicians. The owner or management is exclusively responsible for storing the documentation relative to qualified personnel.

The range of Master 28 tyre changers is designed for mounting, demounting and inflating tyres for light vehicles (cars, not trucks nor motorcycles) with a maximum external diameter of 40 inches and a maximum width of 14 inches.

Additional copies of this manual and the documentation enclosed with the machine can be requested from Corghi, specifying the machine type and serial number.

CAUTION: Design details are subject to change. Some illustrations may vary slightly in appearance from the machine you have.

1.2 FOR YOUR SAFETY

DESCRIPTION OF THE HAZARD

These symbols identify situations that could be detrimental to your safety and/or cause equipment damage.



DANGER



DANGER: It indicates an imminent dangerous situation that, if not avoided, could lead to serious injury or death.



CAUTION



CAUTION: It indicates a potentially dangerous situation that, if not avoided, could lead to serious injury or death.



WARNING



WARNING: It indicates a potentially dangerous situation that, if not avoided, could cause slight or mild injuries.

CAUTION

CAUTION: Used without the safety hazard symbol indicates a potential situation of hazard that, if not avoided, could cause material damage.

EN

1.2.a. GENERAL WARNINGS AND INSTRUCTIONS



CAUTION

Proceed with caution to prevent any injuries. Carefully read, understand and follow the warnings and instructions given in this manual. This manual is an integral part of the product. For future reference, store it together with the machine in a safe place.

1. Accidents could occur if the maintenance procedures described in this manual are not executed correctly, or if the other instructions it contains are not observed. This manual makes continuous reference to the possibility that accidents can occur. Any accident could lead to serious or fatal injuries to the operator or people nearby, or cause material damage.

2. Overinflated tyres can explode, producing hazardous flying debris that may result in an accident.
3. Tyres and rims that do not have the same diameter “do not correspond”. Never attempt to mount or inflate tyres and rims that do not correspond. For example, never mount a 16.5” tyre on a 16” rim and vice versa. It is very dangerous. Tyres and rims that do not correspond could explode and cause accidents.
4. Never exceed the inflation pressure for the tyre indicated by the manufacturer on the side of the tyre itself. Carefully check that the air hose is well inserted in the valve
5. Never bring your head or other body parts close to a tyre during inflation or bead insertion operations. This machine is not a safety device against the possible risk of explosion of tyres, air chambers or rims.
6. Maintain a suitable distance from the tyre changer while inflating. Do not approach it.



DANGER

A bursting tyre can cause projections of its parts in surrounding areas with a force sufficient to cause serious injury or death.

Do not mount a tyre if its dimensions (indicated on the side) do not correspond exactly to the rim dimensions (printed inside the rim) or if the rim or the tyre is defective or damaged.

Never exceed the pressure recommended by the tyre manufacturer.

The tyre changer is not a safety device and does not prevent tyres and rims from exploding. Keep all persons not working on the machine out of the working area.

7. Risk of crushing. Presence of moving parts. Contact with moving parts can cause accidents.

The machine can only be used by one operator at a time.

- Keep bystanders away from the tyre changer.
- Keep your hands and fingers away from the rim edge during the demounting and mounting process.
- Keep hands and fingers clear of mount/demount head during operation.
- Keep your hands and other body parts away from moving parts.
- Do not use tools other than those supplied with tyre changer.
- Use lubricant that is specific for tyres in order to prevent tyre seizure.
- Pay attention while handling the rim or the tyre and while using the lever



8. Danger of electric shock.

- Do not clean electric parts with water or high pressure air jets.
- Do not operate the machine in the presence of a damaged electrical cable.
- If an extension is necessary, use a cable with rated features equal to or greater than those of the machine. Cables with rated features that are lower than those of the machine could overheat and cause a fire.



- ***Make sure that the cable is positioned so that it cannot be pulled and the risk of tripping is avoided.***

9. Risk of eye injuries. During the bead insertion and inflation phase, debris, dust and fluids could be projected into the air. Remove any debris present on the tyre tread and on the tyre surface. Wear protective goggles with OSHA, CE approval or other certified devices during all work phases.



10. Always carefully inspect the machine before using it. Missing, damaged or worn equipment (including the hazard adhesive labels) must be repaired or replaced before start-up.

11. Never leave nuts, bolts, tools or other materials on the machine. They could be entangled in moving parts and cause malfunctions or be ejected.

12. Do NOT mount or inflate tyres that are cut, damaged, decayed or worn. Do NOT mount tyres on damaged, bent, rusted, worn, warped or deformed rims.

13. Should the tyre get damaged during the mounting phase, do not try to complete the mounting operation. Remove it, take it away from the service area and mark it as damaged.

14. Inflate tyres in gradual steps, while continuously monitoring the pressure and observing the tyre itself, the rim and the bead. NEVER exceed the pressure limits indicated by the manufacturer.

15. The internal parts in this equipment could create contacts or sparks if exposed to flammable vapours (petrol, paint thinners, solvents, etc.). Do not install the machine in a narrow area or position it below floor level.



16. Do not operate the machine while under the influence of alcohol, medicines and/or drugs. If you are taking prescription or non-prescription medicines, contact a physician to be aware of the side effects that they might have on the ability to operate the machine safely.

17. Always use OSHA, CE approved and authorised personal protective equipment (PPE) or equipment with equivalent certifications while operating the machine. Consult your supervisor for additional instructions.



18. Do not wear jewellery, watches, loose clothing, ties and tie up long hair before using the machine.

19. Wear protective, non-slip footwear while using the tyre changer.











20. While positioning, lifting or removing wheels from the tyre changer, wear an appropriate back support and use a correct lifting technique.

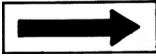









EN



21. Only appropriately trained personnel can use, service and repair the machine. Repairs must only be performed by qualified personnel. Corghi technicians are the most qualified individuals. The employer must determine if an employee is qualified to carry out any machine repair safely if the operator has attempted to make the repair.
22. Before starting the machine, the operator must pay close attention to the warnings of the adhesive labels affixed to the equipment.
23. Clamp the rim on the wheel support plate during inflation.

1.2.b. LABELS PLACEMENT

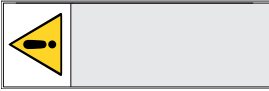
No.	Code	Adhesive	Description
1	446429		LABEL, INPUT PRESSURE MAX. 16 BAR
2	446429		LABEL, ATTENTION TANK PRESSURISED
3	418135		LABEL, ROTATION DIRECTION
4	425211		LABEL, DANGER OF ELECTRIC SHOCK
5	-		LABEL, MODEL SERIAL NUMBER
6	4-105844		LABEL, MOTOR-INVERTER
7	460384		LABEL, CORGHI
8A	4-137513		LABEL, ARTIGLIO MASTER 28 AUTOMATIC
8B	4-137512		LABEL, ARTIGLIO MASTER 28
9	446598		ELECTRIC DISCONNECTION

No.	Code	Adhesive	Description
10	4-104346		UP-DOWN PED. LIFTER (OPTIONAL)
11	461932		PLATE ROTAT.
12	461933		INFLATION PED.
13	446436		DEFLATION PRESSURE GAUGE
14	461936		PROHIBITION OF TWO OPERATORS WORKING SIMULTANEOUSLY
15	346855		ADHESIVE SAFETY STRIP Y/B 50X130
16	462081		RISK OF CRUSHING
17	461930		RISK OF CRUSHING
18	462080		HEARING PROTECTION PLATE
19	461931		INFLATION WARNING PLATE
	462778		USA HAZARD PLATE

EN

No.	Code	Adhesive	Description
20	4-135325		LABEL "TECHNOLOGY PARTNER"
21	4-137859		LABEL, MASTER 28
22	461934		LABEL, WHEEL LOCKING/ UNLOCKING PEDAL (AUTOMATIC VERSION ONLY)

HAZARD LABELS KEY



code 462081 Risk of crushing



part n. 461930 Risk of crushing



Part n. 461936. Never stand behind the machine.
Only one operator may operate and use the machine



part n. 446442. Danger - pressurised container



part n. 425211A. Risk of electrocution.



part n. 425083. Earth ground terminal.

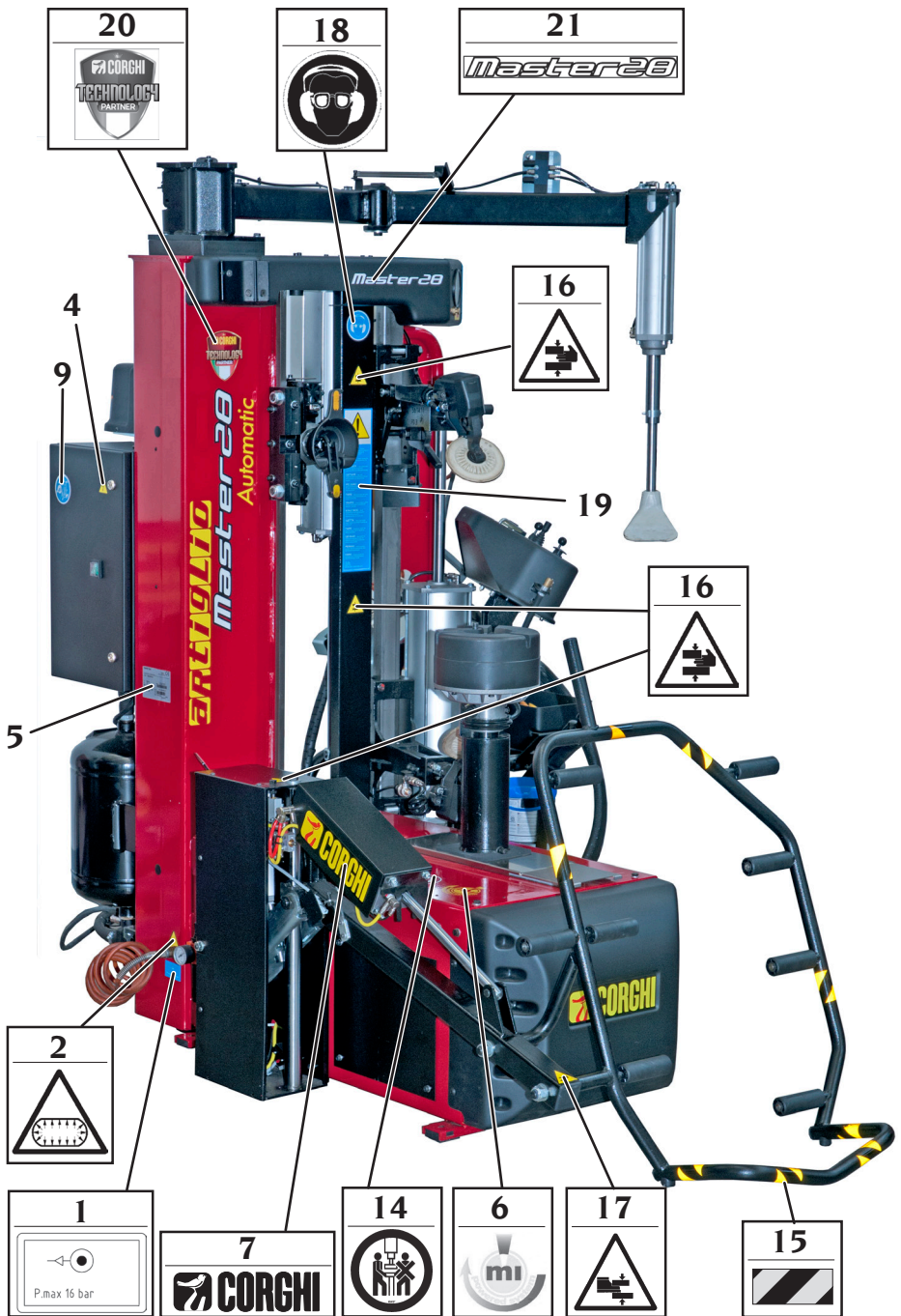

EN

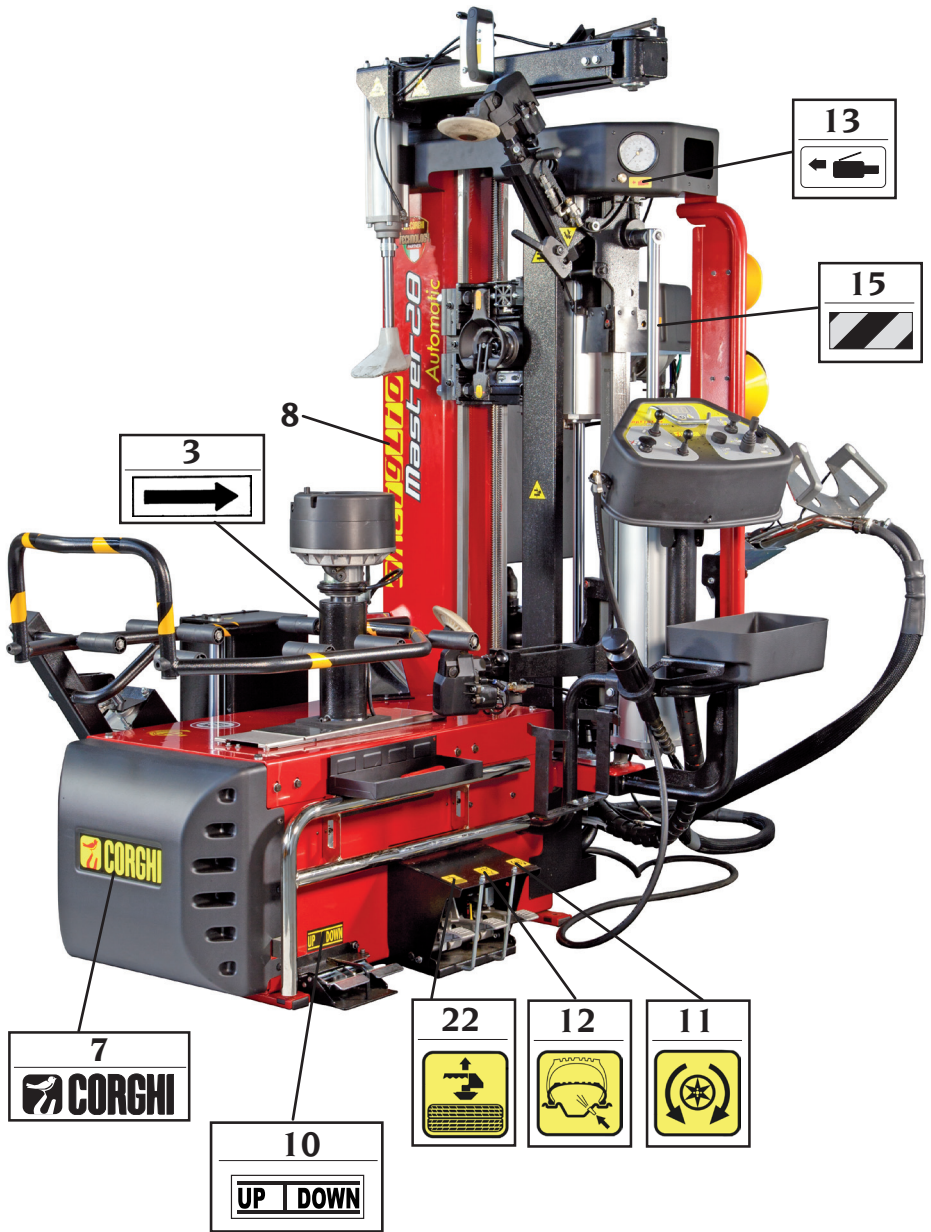

3
→

13
←

15
▬ ▬ ▬

7
CORGI

10
UP | DOWN

22
↑ ↓

12
⚠

11
↻

1.2.c. ELECTRICAL AND PNEUMATIC CONNECTIONS

The electric connection used must be suitably sized:

- for the electric power absorbed by the machine, indicated on its data plate (Fig. 1);
- the distance between the operating machine and the power supply connection point, to ensure that the voltage drop under full load does not exceed 4% (10% during start-up) of the rated voltage value specified on the plate.

- User must:

- fit a power plug in compliance with current regulations on the power supply lead;
- connect the machine to its own electrical connection - A, Fig. 2 - equipped with a differential automatic circuit breaker with 30mA sensitivity;
- install protection fuses on the power line that are suitably sized in accordance with the indications provided on the machine data plate (Fig. 1);
- connect the machine to an industrial socket; the machine must not be connected to domestic sockets.

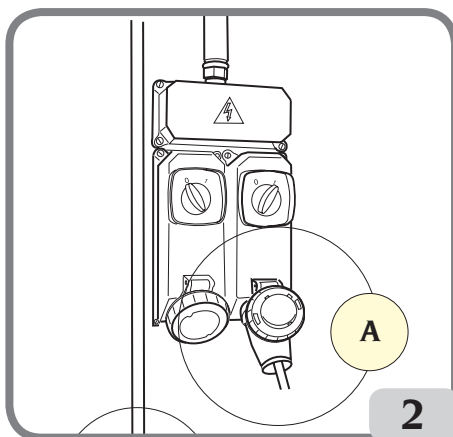
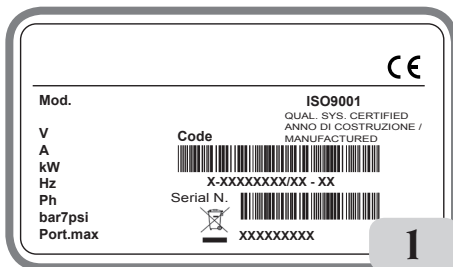

CAUTION

A good earth connection is essential for correct operation of the machine.

EN

Make sure that the available pressure and performance of the compressed air system are compatible with what is necessary for correct machine operation - see the section "Technical data". For correct machine operation, the compressed air supply line must provide a pressure range from no less than 8.5 bar to no more than 16 bar and guarantee an air flow rate greater than the average consumption of the machine, which is equal to 140 NI/min (see technical data).

CAUTION

For correct equipment operation, the air produced must be suitably treated (not above 5/4/4 according to standard ISO 8573-1).

1.2.d TECHNICAL DATA

- Type of tyres

CONVENTIONAL–LOWPROFILE-
RUN FLAT - BALLOON - BSR

- Wheel size range:

- rim diameter from 13" to 28"
- maximum tyre diameter 1100 mm (40")
- maximum tyre width 360 mm (14")

- Turntable: ¹

- automatic positioning in relation to tools
- resting side..... flanged
- centring..... on cone
- clamping manual (automatic for "AUTOMATIC" version)
- drive system..... 2-speed motor-inverter

- Bead breaker:

- bead breaking force 7600N

- Supply:

- operating pressure: 8 -10 bar
- minimum air flow rate: 140 NI/min

- Drive systems

Motor rating	kW	Rotation speed (rpm)	Torque Nm	Weight of electric/ electronic parts (kg)
230V/1ph 50/60Hz MI	0.98	7 - 18	1100	10.2
110V/1ph 50/60Hz MI	0.98	7 - 18	1100	10.2

- Lifter:

- max capacity..... 85 kg

- **Weight** 470 kg (T.I version 480 kg)

- Noise level:

- A-weighted sound pressure level (LpA) at the working position < 70 dB (A)

The noise levels indicated correspond to emission levels and do not necessarily represent safe operating levels. Although there is a relationship between emission levels and exposure levels,

this cannot be used reliably to establish whether or not further precautions are necessary. The factors which determine the level of exposure to which the operator is subject to include the duration of the exposure, the characteristics of the workplace, other sources of noise, etc. The permitted exposure levels may also vary according to the country. In all cases, this information will enable machine users to better assess the danger and risks involved.

1.2.e. AIR PRESSURE

The machine is equipped with an internal pressure limiting valve to minimize the risk of over inflating the tyre.

	<p style="text-align: center;"> DANGER</p> <ul style="list-style-type: none">• RISK OF EXPLOSION• Never exceed tyre pressure recommended by tyre manufacturer. Always match the tyre and rim dimensions.• Take care to avoid any injuries.
---	---

1. Never exceed these pressure limitations:

- The supply circuit pressure (from the compressor) is **220 psi (15 bar)**.
- The operating pressure (indicated on the regulator) is **150 psi (10 bar)**.
- The tyre inflation pressure (displayed on the pressure gauge) must never exceed the pressure indicated by the manufacturer on the sidewall of the tyre itself.

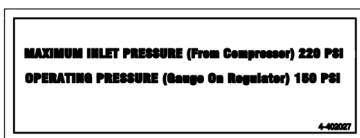

2. Activate the air inflation jets only when inserting the bead.
3. Discharge the air pressure system before disconnecting the power supply or other pneumatic components. Air is stored in a reservoir to operate the inflation jets.
4. Activate the air inflation jets only if the rim is correctly clamped on the tyre changer (if required) and the tyre is completely mounted.

EN

1.3. ADDITIONAL RIM/TYRE INFORMATION

<p style="text-align: center;">CAUTION</p> <p>Wheels equipped with pressure sensors and special rims or tyres could require particular work procedures. Consult wheels and tyre manufacturer's service manuals.</p>

1.4. INTENDED MACHINE USE

This machine must only be used to demount and mount vehicle tyres from/on the rims, using the provided tools. Any other use is improper and may result in injury. The machine is not designed for working with motorcycle wheels.

1.5. PERSONNEL TRAINING

1. Employers are responsible for providing a training program for all employees who work on the wheels concerning the hazards deriving from maintenance and the safety procedures to be observed. Service or maintenance refer to mounting and demounting wheels and all the correlated activities, such as inflation, deflation, installation, removal and handling.
 - Employers are required to make sure that operators do not work on the wheels unless they have received suitable training regarding the correct maintenance procedures for the type of wheel being serviced and the operative safety procedures.
 - Information to be used for the training program includes, as a minimum, the information contained in this manual.
2. Employers are required to make sure that every employee demonstrates and maintains the ability to work on the wheels safely, including the performance of the following activities:
 - Demounting of tyres (including deflation).
 - Inspection and identification of the rim wheel components.
 - Tyre mounting.
 - Use of any restraint device, cage, barrier, or other systems.
 - Handling of wheels with rims.
 - Tyre inflation.
 - Move away from the tyre changer while inflating the tyre and do not lean forward when inspecting the wheel during inflation.
 - Wheel installation and removal.
3. Employers must evaluate the ability of their employees to carry out these tasks and work on the wheels in absolute safety and must provide additional training as required to make sure that all employees maintain their skills.

1.6. PRELIMINARY CHECKS

Before starting to work, carefully check that all machine components, particularly rubber or plastic parts, are in place, in good condition and operate correctly. If the inspection reveals any damage or excessive wear, no matter how slight, immediately replace or repair the component.

1.7. DURING USE

If strange or unusual noises are heard or any unusual vibration is detected, if a component or system is not operating correctly or if you observe anything unusual, immediately stop using the machine.

- Identify the cause and implement all the necessary corrective measures.
- Contact your supervisor if necessary.

Make sure that all other people are standing at least 6 metres (20 feet) from the machine.

To switch off the machine in case of emergency:

- disconnect the power supply plug;
- interrupt the compressed air supply by disconnecting the supply pipe.

2. TRANSPORT, STORAGE AND HANDLING

Machine transport conditions

The tyre changer must be transported in its original packing and kept in the position indicated on the packing.

- Packing dimensions:

- width 1950 mm
- depth 1950 mm
- height 2100 mm

- Weight with wooden crate:

- Standard version 570 kg
- TI version 590 kg

Ambient conditions for machine transport and storage

Temperature: $-25^{\circ} \div +55^{\circ}\text{C}$.

CAUTION

Do not stack other goods on top of the packing to avoid damaging it.

Handling

To move the packing, insert the forks of a forklift truck into the slots on the base of the packing itself (pallet) (Fig.3).

Before moving the machine, refer to the LIFTING/HANDLING section.

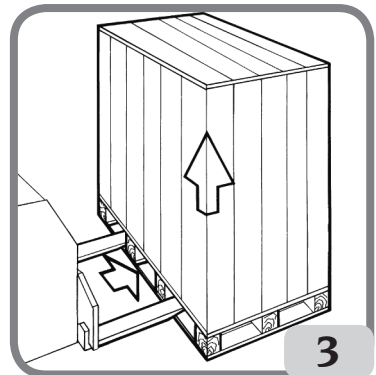

EN

CAUTION

Keep the packing material intact for possible future transport of the machine.

2.1. UNPACKING

Remove the upper part of the packaging and make sure the machine has not been damaged during transport.

3. ASSEMBLY/HANDLING

CAUTION

Pay careful attention when unpacking, assembling, handling and installing the machine as described below. Failure to observe these instructions could damage the machine and compromise operator safety.

CAUTION

Before removing the machine from the pallet, make sure the items shown below have been removed.

- Remove the upper part of the cardboard packaging and make sure the machine has not been damaged during transport. Identify the fixing points (Fig.4 - "F") on the pallet

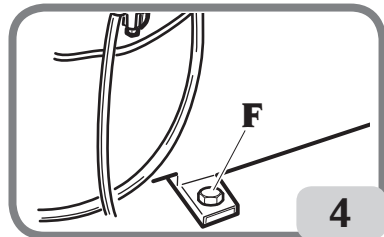

- The machine packaging includes the following units (fig. 5):
 - A) Outfit
 - B) Roll-Bar
 - C) Bead pressing tool
 - D) Pressure gauge unit

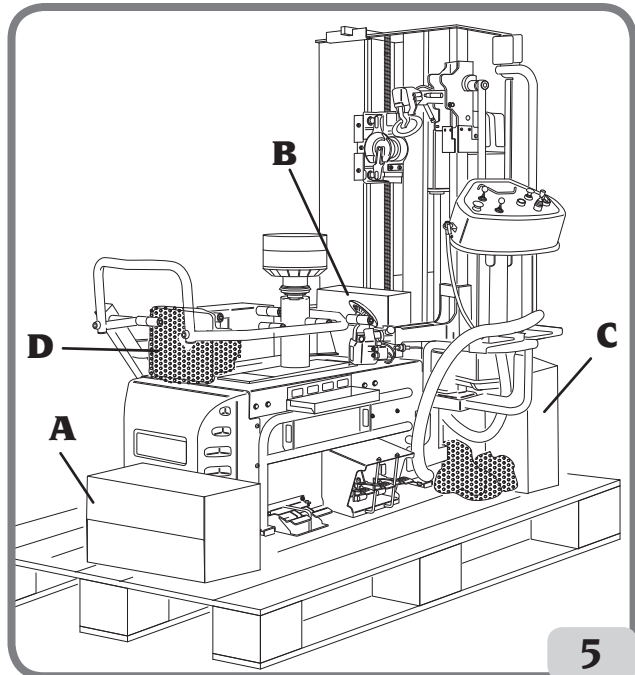

3.1. LIFTING/HANDLING

To lift the machine from the pallet, remove the screws from the fixing foot (A, Fig. 6) and secure it using the hoisting bracket (B, Fig. 6).

This lifting point must be used whenever you need to change the position of the machine. Do not attempt to move the machine until it has been disconnected from the power and pneumatic supply networks.

3.2. INSTALLATION

- Remove the hoisting bracket by loosening the screw and the relevant washer (Fig. 6a).
- Remove the pressure gauge holder cover from its packaging.
- Connect pipeline (A, Fig. 7) to union (B, Fig. 7).
- Place the cover on the tyre changer and secure the upper part using the 3 M6 screws (C, Fig. 8).
- Fix the cover laterally using the 2 M4 screws (D, Fig. 9)
- Remove the bead pressing unit from the packing.
- Place the spacer of the bead pressing tool support correctly on the tyre changer (see Fig. 10)
- Place the bead pressing tool support on the

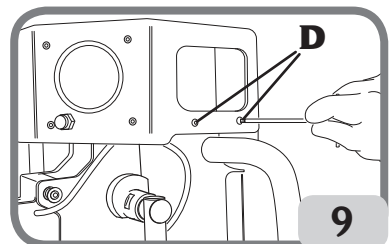
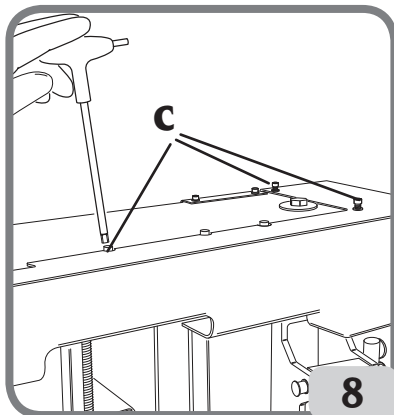
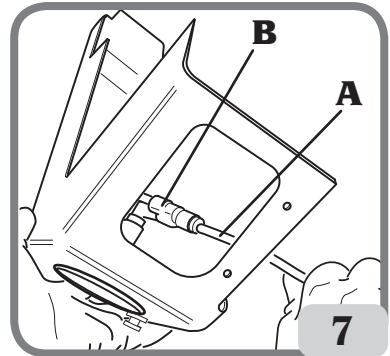
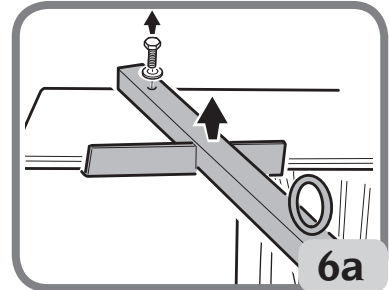
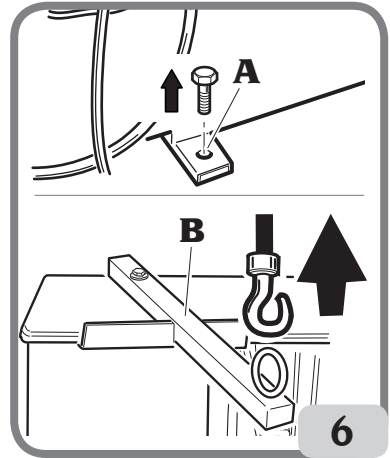

EN

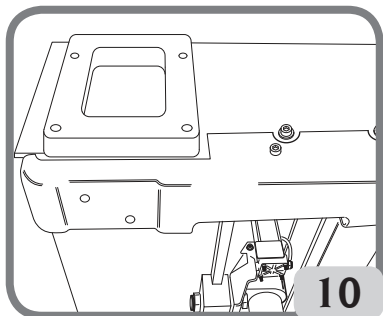

spacer, then fix it using the 4 M8 screws supplied (see Fig. 11).

- Grease the seat of the pivot pin and then position the spacer (E, Fig. 12) and the shims (F, Fig. 12).

- Using a suitable lifting device, position the bead pressing arm on the support, verifying the exact positioning of the spacer and shim.

- Insert the pivot pin (F, Fig. 13) and fix it to the support by means of the M8 screw (G, Fig. 13) supplied.

- Secure the two spring brackets (H, Fig. 14 and H1, Fig. 14a) using the M6 screws supplied, then position the springs (I, Fig. 14 and I1, Fig. 14a).

- Fasten the bead pressing tool supporting plate to the cover (L, Fig. 15) by means of the 2 M6 screws (M, Fig. 15) supplied.

- Connect the bead pressing tool pipe (N, Fig. 16) to the T-shaped fitting of the filter/regulator unit (O, Fig. 16).

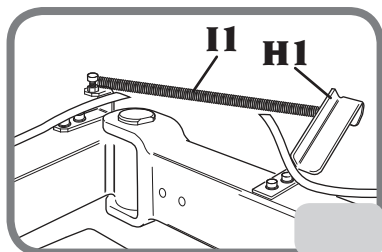
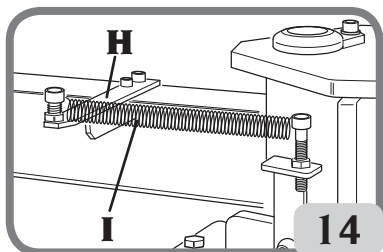
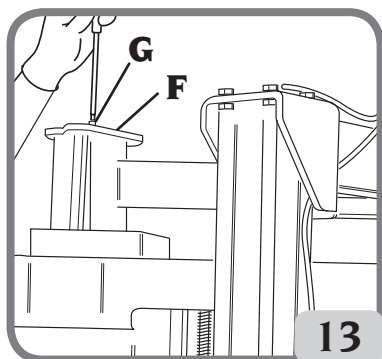
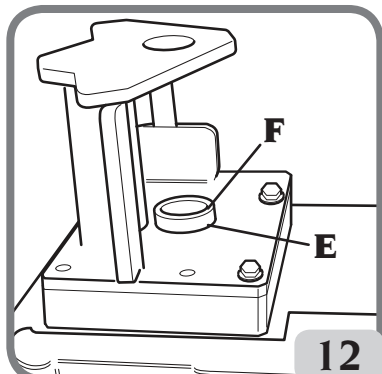
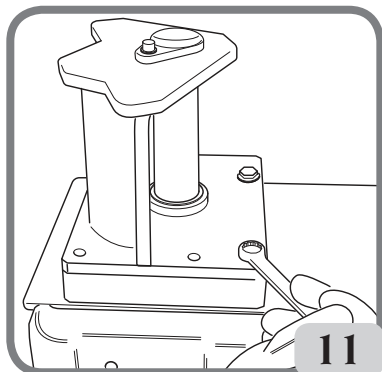

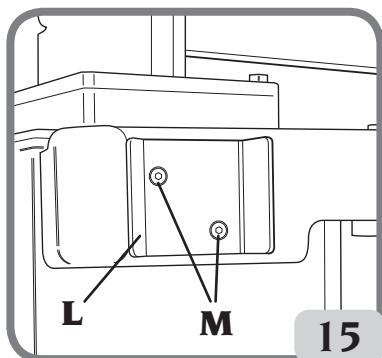

- Place the bead pressing tool on its arm (see Fig. 17).
- Fix the object holder on its support using the 2 provided screws (Fig. 18).
- Connect the machine to the power supply and the compressed air supply lines.

FOR T.I. VERSIONS ONLY:

- Fix the inflation handle support to the tyre changer (P, Fig. 19) using the screw (Q, Fig. 19) supplied.
- Place the inflation handle on the support (see Fig. 19a).

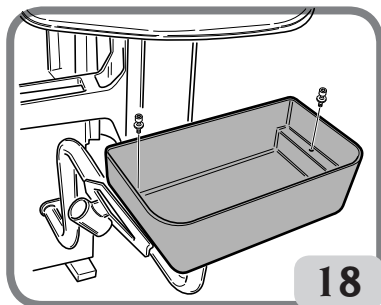
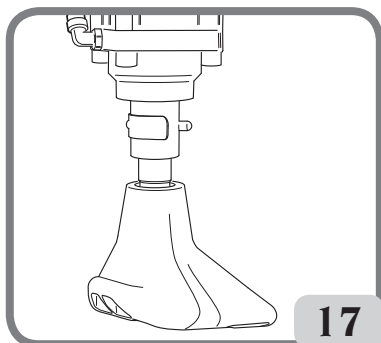
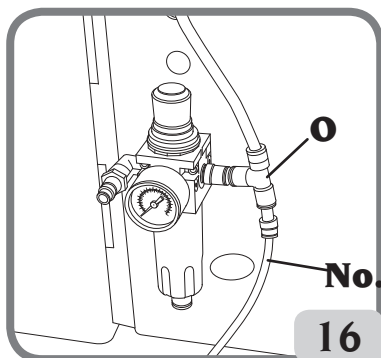

EN

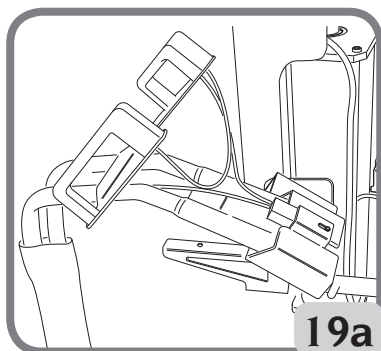
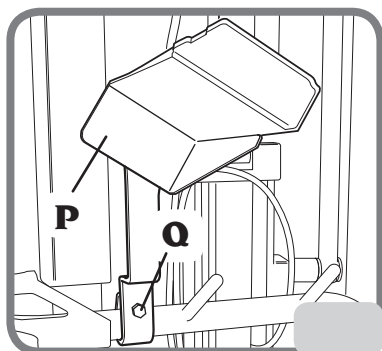

4. INSTALLATION AREA

CAUTION

Install the machine in compliance with all the applicable safety standards, including, but not limited to, those issued by OSHA.

DANGER

RISK OF EXPLOSION OR FIRE. Do not use the machine in areas that could be exposed to inflammable vapours (petrol, paint solvents, etc.).
Do not install the machine in a narrow area or position it below floor level.

WARNING

IMPORTANT: for the correct and safe operation of the equipment, the ambient lighting level should be at least 300 lux.

Do not install the machine outdoors. It is designed to be used in closed, covered areas.

Install the tyre changer in the chosen work position, complying with the minimum clearances shown in **Fig.16**

The support surface must have a load-bearing capacity of at least 1000 kg/m².

Ambient working conditions

- Relative humidity 30% ÷ 95% without condensation.
- Temperature 0°C ÷ 50°C.

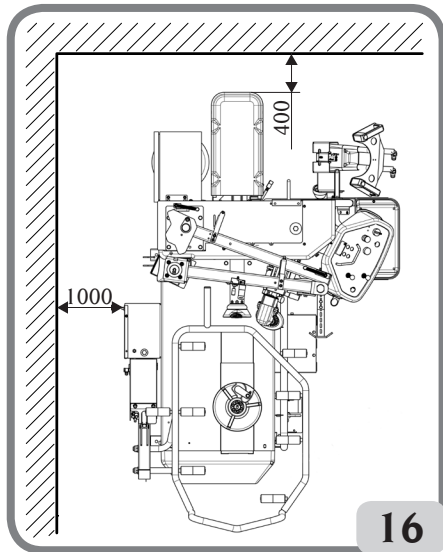

5. ARTIGLIO MASTER 28 DESCRIPTION

Artiglio Master 28 is an electropneumatically operated universal tyre changer to change car, off-road and light commercial vehicle tyres.

Artiglio Master 28 makes it easy to easily break, demount and mount any type of tyres with a rim diameter between 13” and 28”.

Additional improvements were made:

- to reduce the physical exertion of the operator;
- to guarantee rim and tyre safety;
- to automate, as far as possible, operations that up until now have been manually performed by the operator.

Each machine carries a plate Fig. 17 reporting its identification data and some technical data.

As well as the manufacturer's details, it indicates:

- Mod. - Machine model;
- V - Power supply voltage in Volts;
- A - Input voltage in Amperes;
- kW - Absorbed power in kW;
- Hz - Frequency in Hz;
- Ph - Number of phases;
- bar7psi - Operating pressure in bar;
- Serial No. - machine serial number;
- ISO 9001 - company Quality System Certification;
- CE - CE marking.

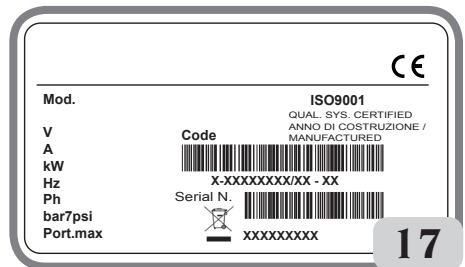

5.1. OPERATOR POSITION

Figure 17a shows the position of the operator (A) during the various work phases.

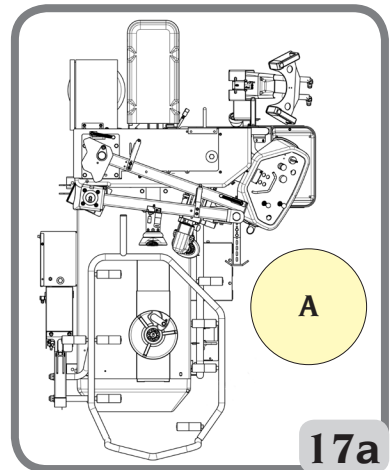

CAUTION

In these conditions, the operator can move away, monitor and check every tyre change operations and take action in the case of any unforeseen events.

5.2. OVERALL DIMENSIONS

- Depth (with lifter) A1 = 1875 mm
- Depth A = 1670 mm
- Width B = 1020 mm
- With (with lifter) B1 = 1176 mm
- Maximum height H = 1824 mm

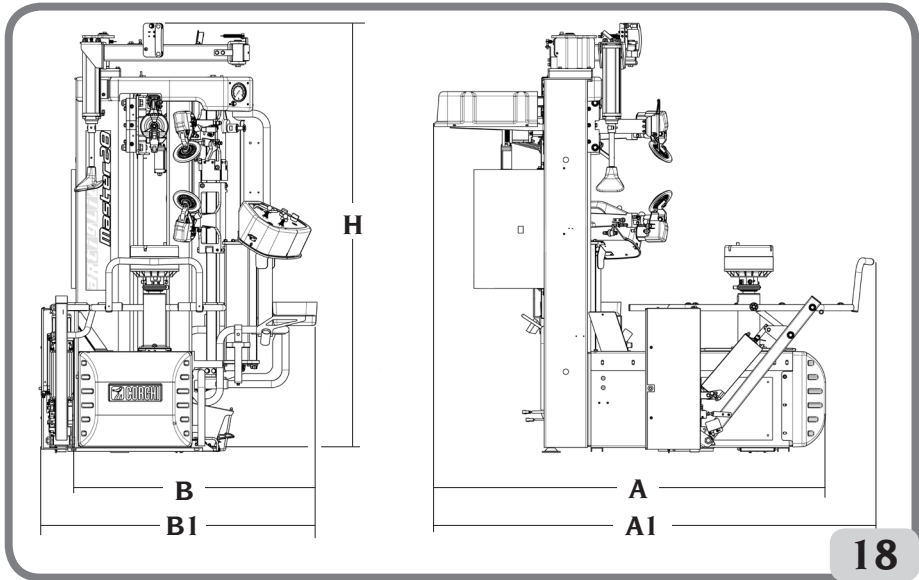

5.3. EQUIPMENT COMPONENTS (MAIN WORKING OPERATING ELEMENTS OF THE MACHINE)

The main machine parts are indicated in Fig. 19.

- 1) Control console
- 2) Pressure gauge with deflation push-button
- 3) Frame
- 4) Upper bead breaker disc
- 5) Upper bead breaker disc release lever
- 6) Upper bead breaker disc positioning lever
- 7) Lower bead breaker disc
- 8) Movable tool
- 9) Tool head
- 10) Fixed tool
- 11) Bead pressing tool

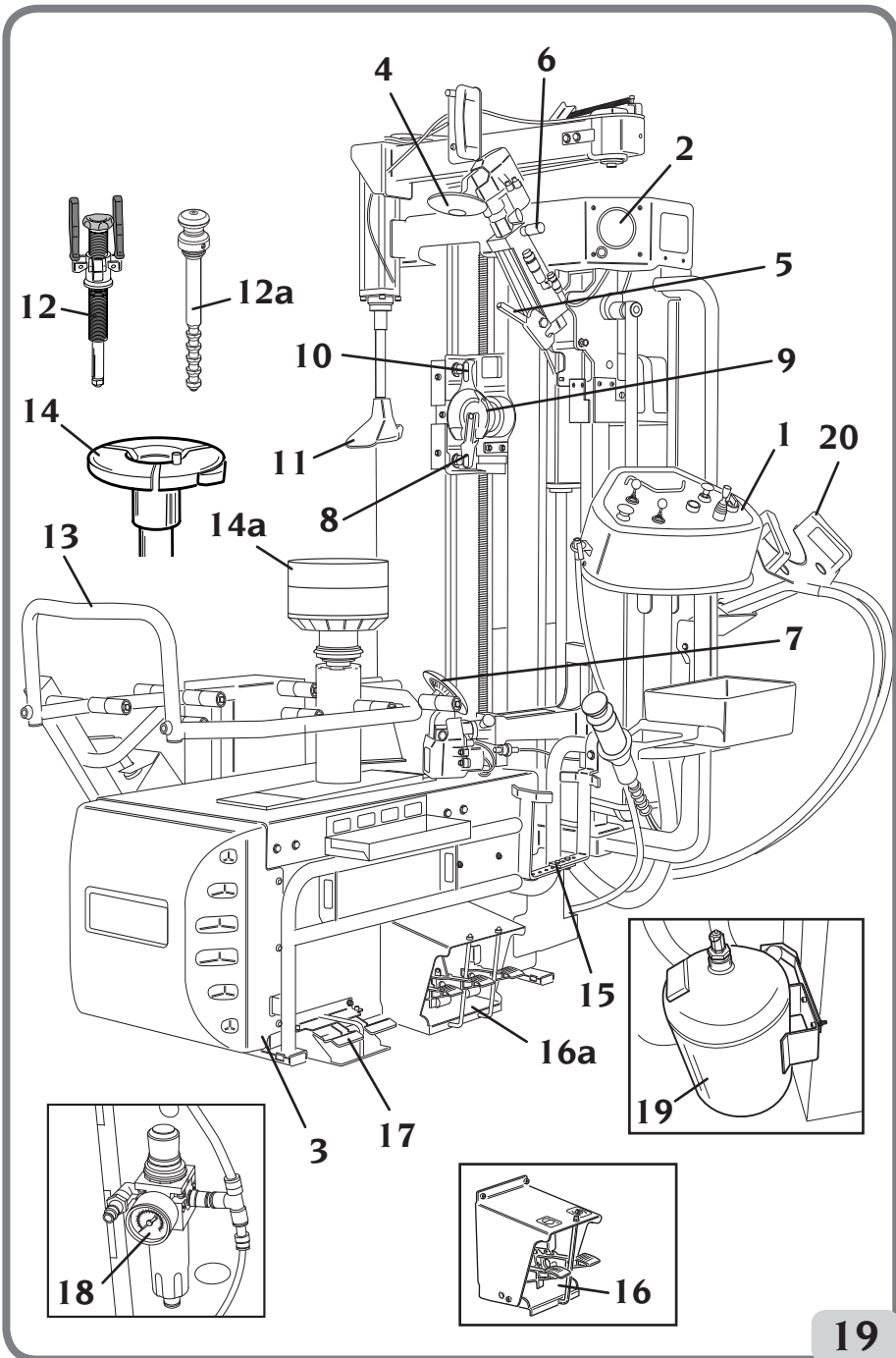

- 12) Centring handle
- 12a) Centring handle (for automatic version)
- 13) Wheel lifter (optional)
- 14) Turntable
- 14a) Turntable (for automatic version)
- 15) Grease support
- 16) Pedal unit
- 16a) Pedal unit (for automatic version)
- 17) Wheel lifter pedal unit (optional)
- 18) Regulator filter
- 19) Tank (optional)
- 20) T.I. (optional)

CAUTION

Get to know your machine: knowing exactly how the machine works is the best way to guarantee safety and machine performance. Learn the functions and location of all controls.

Carefully check that all controls on the machine are working properly.

The machine must be installed properly, operated correctly and serviced regularly in order to prevent accidents and injuries.

CAUTION

With regard to the technical characteristics, warnings, maintenance and any other information about the air tank (optional), consult the relevant operator's and maintenance manual provided with the documentation of the accessory.



5.4. CONTROLS

5.4.a. ON/OFF SWITCH

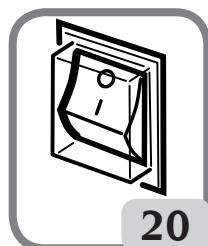

20

5.4.b. CONTROL CONSOLE

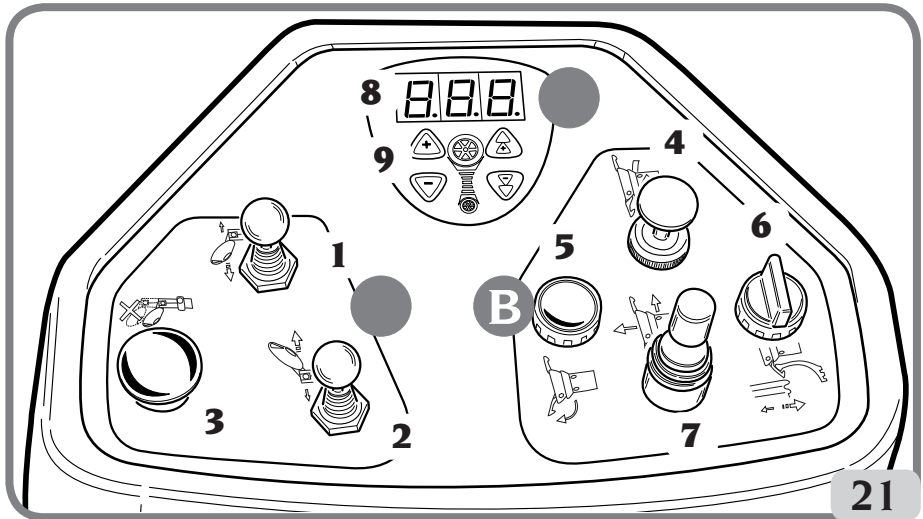

Area A – Bead breaker functional controls



1 - Operating lever for upper bead breaker disc vertical movement.



2 - Operating lever for lower bead breaker disc vertical movement.



3 - Push-button for simultaneous penetration of upper and lower bead breaker

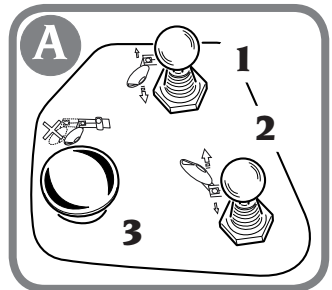

EN

Area B – Tool head functional controls



4 - Push-button for 180° head rotation.



5 - Button to operate the movable tool to select the upper bead.



6 - Selector to operate the movable tool for upper bead demounting.

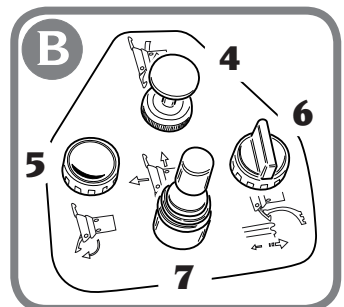

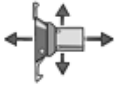

7 - Head movement control lever.

Area C – Rim diameter display and rim diameter configuration keyboard

8 - Display showing the rim diameter

The number displayed has two digits with a decimal separator.

9 - Keyboard for rim diameter configuration

The keyboard is divided into:

- keys for entering numerical values for the unit. Use the keys to enter unit values, increasing (+) or decreasing (-) them;
- keys for entering decimal numerical values. Use the keys to enter the values, increasing (+) or decreasing (-) them.

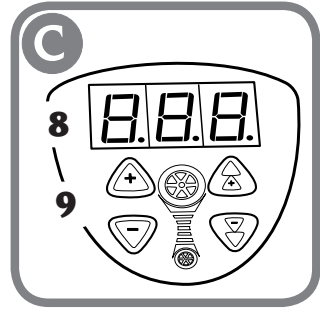

5.4.c. PEDAL UNIT



1 - Inflation pedal.



2 - Turntable rotation pedal.

The pedal has 4 different operating positions, each corresponding to a rotation speed.

- pedal raised (unstable position): slow anticlockwise rotation. If the pedal is kept raised for more than 4 seconds, rotation gets faster (always anticlockwise)
- pedal in the rest position (stable position): turntable stopped
- pedal gently pressed downwards (unstable position): slow clockwise rotation
- pedal pressed entirely downwards (unstable position): fast clockwise rotation

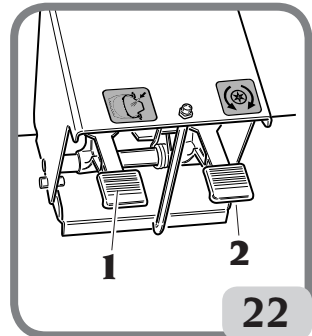

PEDAL UNIT (“AUTOMATIC” VERSION)



3 - Wheel locking/unlocking pedal.

The automatic version features a third pedal.

Pressed to release the system which locks the turntable centring handle. In its rest position, the system which clamps the turntable centring handle is normally active. The pedal is used during positioning and clamping of the wheel on the turntable, and to release the wheel when the job is done.

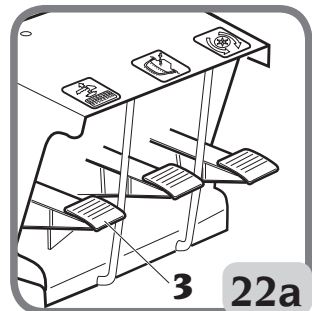

5.4.d. WHEEL LIFTER PEDAL UNIT (Fig. 23) (optional)

UP

1 - Pedal pressed (unstable position):
hands-on wheel lifting

DOWN

2 - Pedal pressed (unstable position):
hands-on wheel lowering

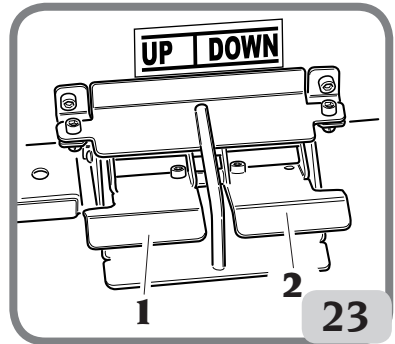

5.4.e. PRESSURE GAUGE WITH DEFLATION PUSH-BUTTON (Fig. 24)

- 1- Pressure gauge displaying air pressure, with pedal regulation
- 2- Deflation button

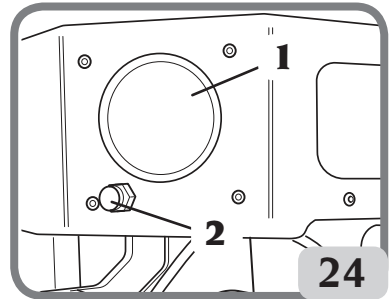

6. BASIC PROCEDURES - USE

! CAUTION

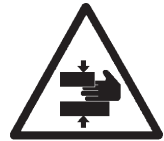
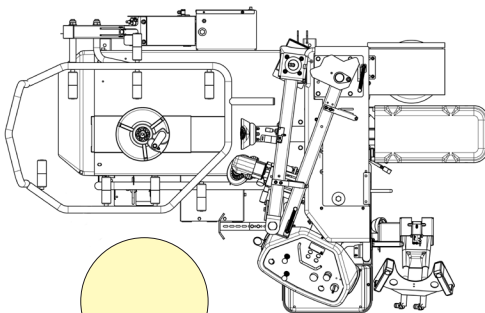

EN

CAUTION

RISK OF INJURY

Before using the machine: Disconnect the power supply Fig. 25; Isolate the compressed air line by disconnecting the supply hose (quick-release connector) Fig. 25A

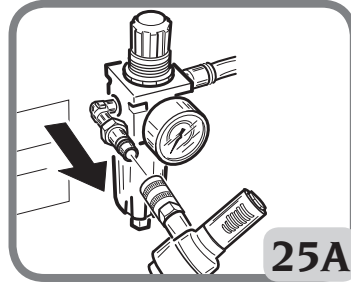
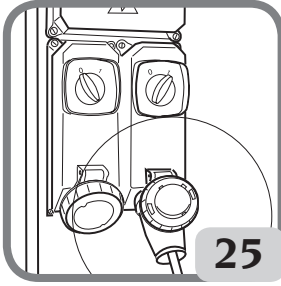

CAUTION

In order to prevent damage or involuntary movement of the machine, it is recommended to only use original Corghi spare parts and accessories.

6.1. PRELIMINARY CHECKS

Check that there is a pressure of at least 8 bar on the filter regulator pressure gauge. If the pressure is below the minimum level, some machine operations may be limited or insufficient.

After the correct pressure has been restored, the machine will function properly.

Check that the machine has been adequately connected to the electric mains and the pneumatic supply.

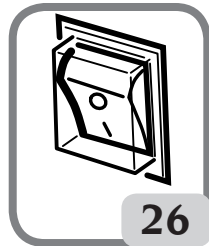

6.2. TURNING THE MACHINE ON

Turn the main switch (Fig. 26) to position -I- (ON).

After turning on the machine, "Att" will appear on the screen (see Fig. 27).

Press any of the numerical value input keys on the keyboard to reset the machine.

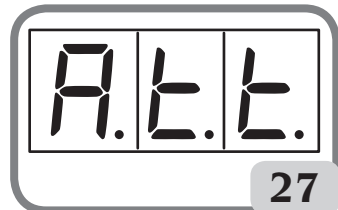

6.3. DECIDING FROM WHICH SIDE OF THE WHEEL THE TYRE MUST BE REMOVED

See Fig.28. Identify the position of channel A on the rims. Identify the greater width B and the smaller width C. The tyre must be mounted and demounted with the wheel on the turntable with the smallest width side C facing upwards.

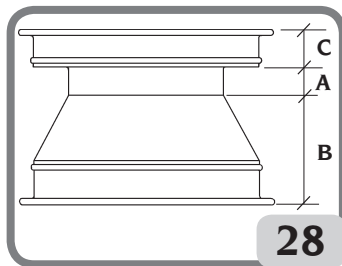

CAUTION

See the paragraph “TABLE FOR USING CENTRING AND CLAMPING ACCESSORIES ACCORDING TO RIM TYPE” in this manual.

When working with “easily deformable” rims (i.e. a central hole with thin, projecting edges - see Fig. 28A) we recommend using the universal flange for closed rims (see the section “TABLE FOR USING CENTRING AND CLAMPING ACCESSORIES ACCORDING TO RIM TYPE” in this manual).

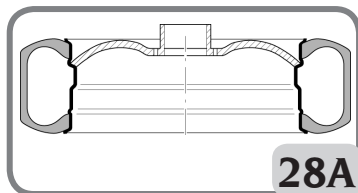

SPECIAL WHEELS

Wheels with alloy rims: some wheels with alloy rims have a minimum A rim channel or do not have any channel - Fig. 28B. These rims are not approved by DOT standards (Department of Transportation). The DOT initials certify that tyres comply with the safety standards adopted by the United States and Canada (these wheels cannot be sold in these markets).

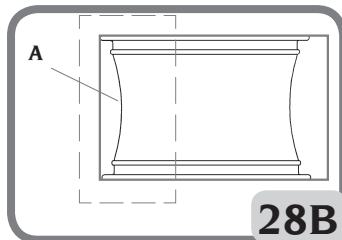

High performance wheels (asymmetric curvature) - Fig. 28C some European wheels have rims with very pronounced curvature C, except in the area of the valve hole A where the curvature is less pronounced B. On these wheels the bead must first be broken in correspondence of the valve hole, on both the top and bottom sides.

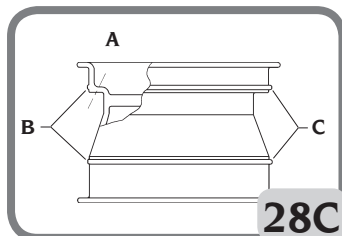

EN

Wheels with pressure sensor - Fig.28D. To work correctly on these wheels and avoid damaging the sensor (which can be incorporated in the valve, secured to the belt, glued inside the tyre, etc.) suitable mounting/demounting procedures must be observed (refer to "Approved mounting/demounting procedure for runflat and UHP tyres").

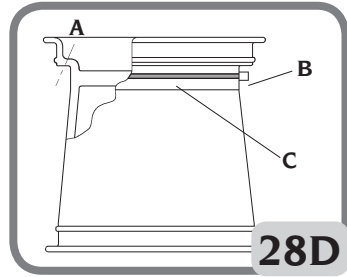

CAUTION

Remove the old weights from the rim before starting work operations.

6.4. WHEEL LOADING

CAUTION

Press the lifter pedals only during the wheel loading/unloading phases.
Never press them during other work phases!

- Press the DOWN pedal to move the lifter to the loading position (Fig. 30).
- Load the wheel onto the lifter (Fig. 30) then press the UP pedal. The wheel will be lifted and positioned horizontally on the turntable (Fig. 31).
- Press the UP pedal again. The lifter will lower and place the wheel on the turntable.

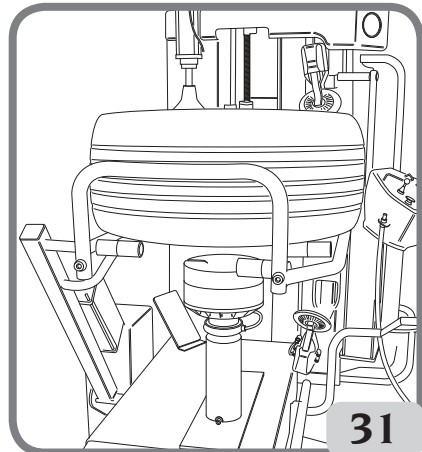
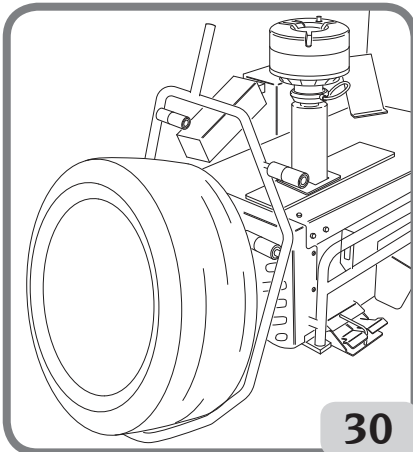

- When positioning the wheel on the turntable, also take care to centre the movable centring pin, placed radially on the turntable, in one of the fixing bolt holes (see Fig. 32).

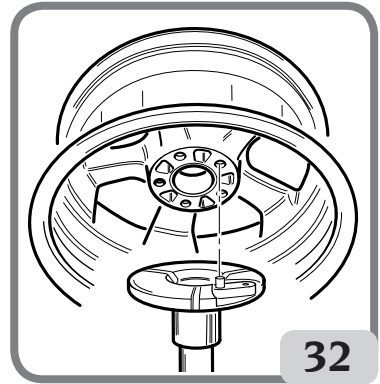

6.5. CLAMPING THE WHEEL ON THE TURNTABLE

- Insert the clamping handle in the central hole of the wheel

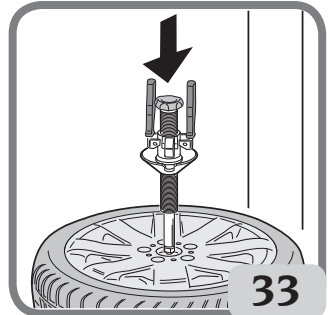

- Turn the handle for correct engagement with the turntable

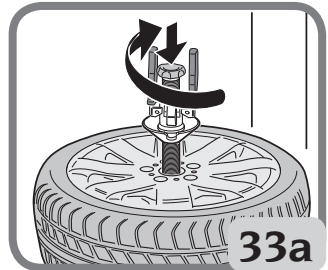

- Manually move the centring cone into position on the rim by moving the retainers "1"

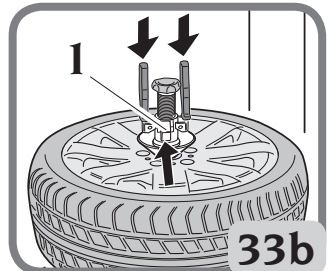

EN

- Tighten the clamping system, turning the handle clockwise

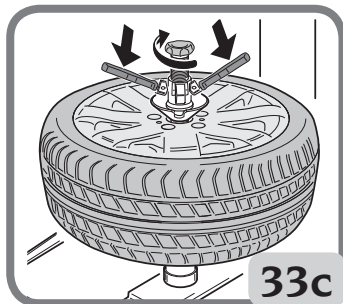

6.5a. CLAMPING THE WHEEL ON THE TURNTABLE (“AUTOMATIC” VERSION)

- Press the Pedal 3 fig. 33d to release the turntable clamping system.
- Take hold of the centring handle 1 fig. 33e and adjust the position of the wheel by hand to fit the serrated rod into its centre hole fig. 33e.
- Release the Pedal 3 fig.33d. The wheel clamping system is now active and the wheel is locked to the turntable by means of the centring handle, moving as one with it.

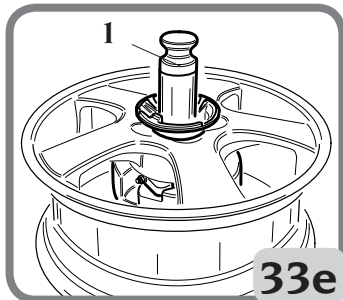
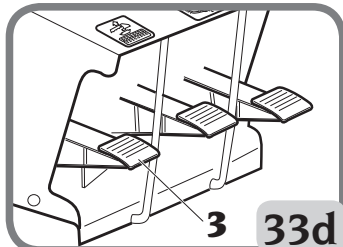
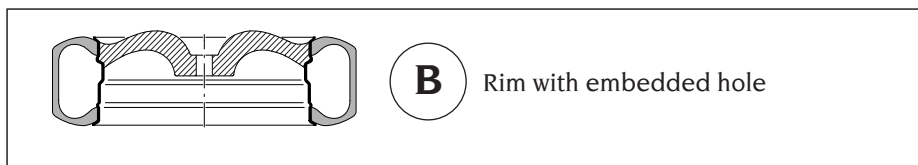
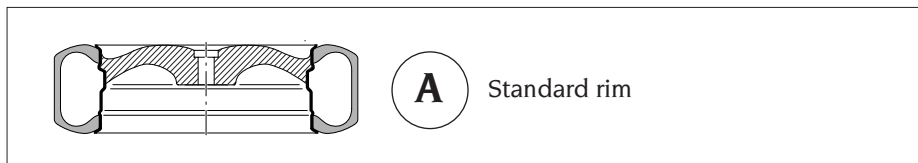
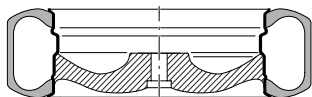
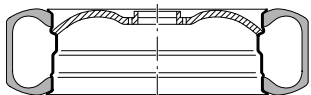

TABLE FOR USING CENTRING AND CLAMPING ACCESSORIES ACCORDING TO RIM TYPE





C Reverse rims



D Rim for vans

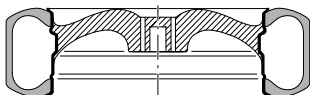

E Rim without central hole

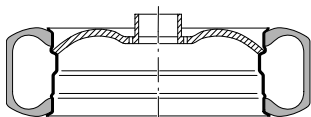

F Rim with central hole



CAUTION

**CRUSHING POINT - MOVING PARTS. Risk of injuries due to crushing.
Keep hands away from the handle or cone during clamping**

EN

6.6. CONFIGURATION OF WHEEL DATA

Set the rim diameter value using the keyboard "9". The rim diameter in inches will appear on display "8". The displayed value consists of two digits with a decimal separator.

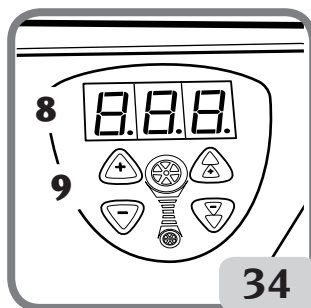

6.7. TYRE DEFLATION

Operate the valve and fully deflate the tyre (Fig. 35)

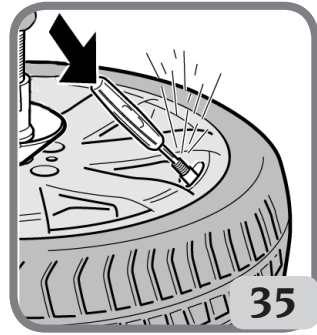

6.8. BEAD BREAKING

<p>CAUTION</p> <p>KEEP YOUR HANDS AND OTHER BODY PARTS AWAY FROM MOVING PARTS</p>	<p>CAUTION</p> <p>KEEP FEET CLEAR OF THE BEAD BREAKER AND LIFTER</p>	<p>CAUTION</p> <p>DO NOT PERFORM BEAD BREAKING IF THERE IS AIR IN THE TYRE</p>
--	---	---

CAUTION

All air pressure inside the tyre must be removed before proceeding. Never attempt to break the bead until all air is removed from the tyre. Failure to remove all air from tyre may result in injury to the operator, or damage to the equipment, the tyre, or the wheel.

1 - Place the upper bead breaking unit in the working position (horizontal arm axis), lowering it manually using the fixed gripping lever (Fig. 36).



2 - Operate the lever and move the disc, taking it to about 5 mm under the rim edge (Fig. 36a).

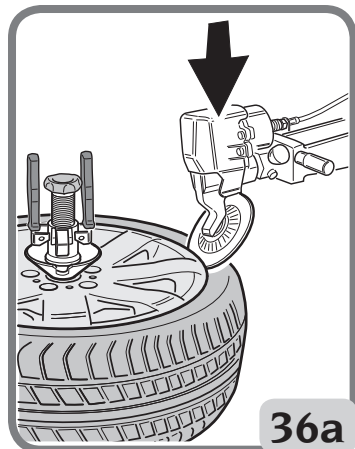
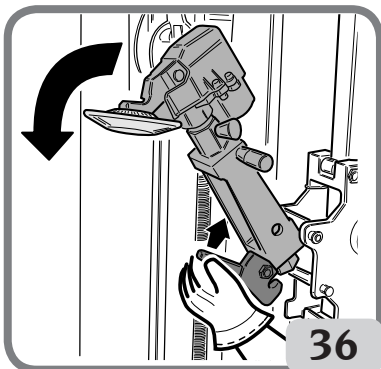

3 - Press the top bead breaker disc penetration button  .

4 - Lubricate the bead to make bead breaking easier (Fig. 36b)

5 - Press the pedal  to turn the turntable.

6 - Operate the control  , tapping on it, to lower the bead breaker disc and fully remove the bead from its seat on the rim.

7 - Make at least one rotation to finish bead breaking.

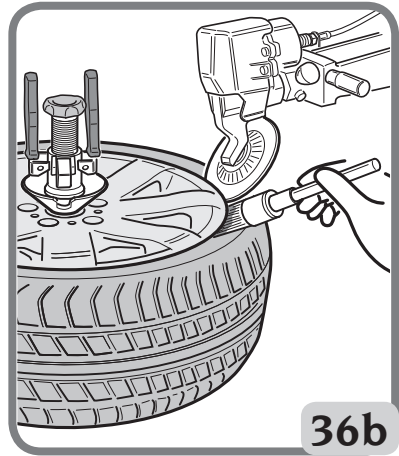

THESE OPERATIONS will completely detach the top bead from the rim (see Fig. 36c).

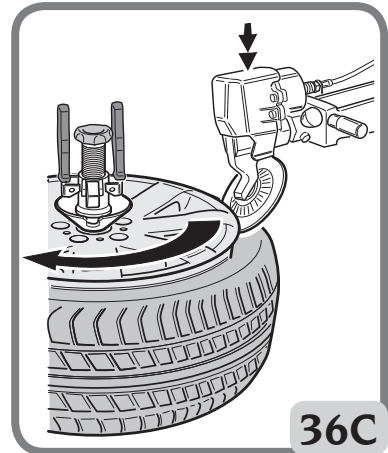

8 - Move the lever  upwards to automatically stop penetration and to withdraw the disc from the work area and move the entire unit upwards, disengaging it from the work area, manually operating the mobile lever located under the arm of the unit, from the operator's side

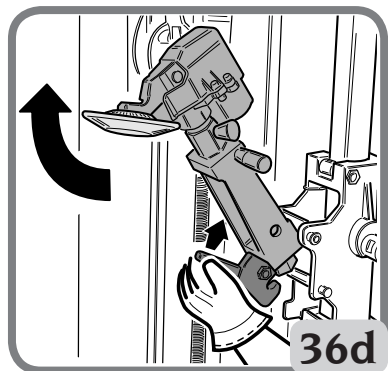

EN

9 - Operate the lever  and move the disc, taking it to about 5 mm above the rim edge (Fig. 36e).

10- Press the button  to activate penetration of the lower bead breaker disc.

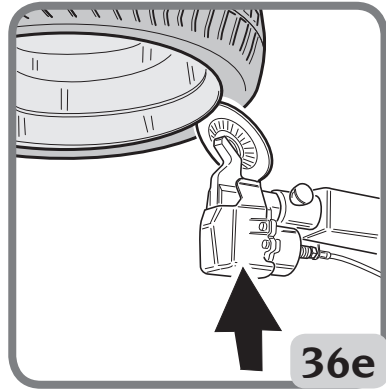

11- Lubricate the bead manually to make bead breaking easier (Fig. 36f).

12- Press the pedal  to turn the turntable.

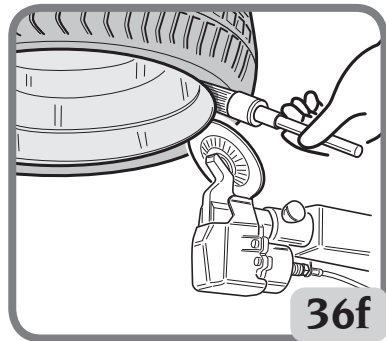

13 - Operate the control , tapping on it, to raise the bead breaker disc and fully remove the bead from its seat on the rim (Fig. 36g).

14- Make at least one rotation to finish bead breaking.

THESE LAST OPERATIONS will completely detach the bottom bead from the rim.

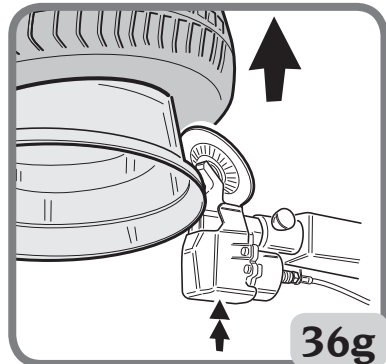

15- Move the lever  downwards to automatically stop penetration and to withdraw the disc from the work area

6.9. DEMOUNTING





CAUTION

Press the lifter pedals only during the wheel loading/unloading phases.
Never press them during other work phases!

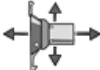
- 1 - Press the button  to move the mobile tool "1" to the position shown in Fig. 37.

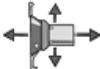
- 2 - Operate the lever  to insert the movable tool completely under the bead (Fig. 37a).
To obtain a more precise position, press the button

located on the top part of the lever  during movement.

- 3- Hold down the button  to hook the bead (Fig. 37b).

Rotate the wheel applying pressure on the pedal

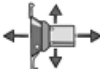

If necessary, operate the control to lower the head

further 

- 4 - After hooking the bead, release the button to return the tool to the rest position (Fig. 37c).

- 5 -  raise the movable tool until the horizontal line of the tool is completely visible (Fig. 37d) - (A Fig. 37e).

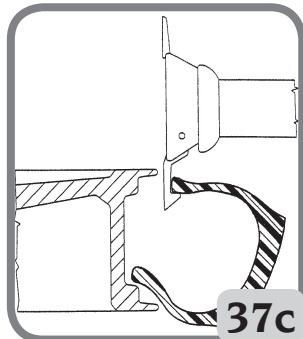
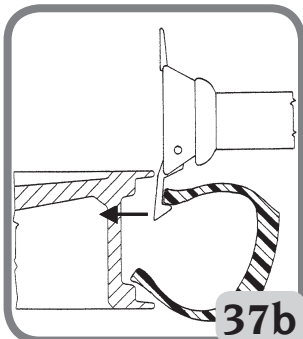
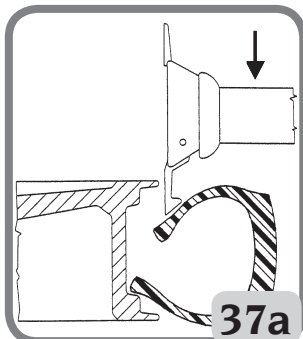
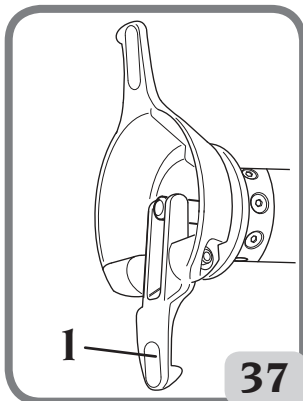

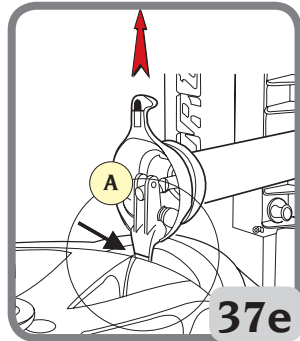
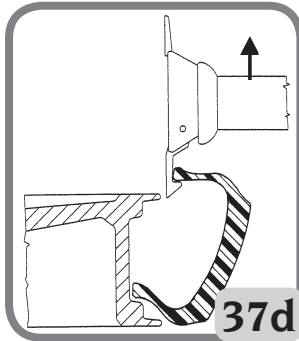

6 - Ensure that the bottom part of the tyre is completely broken, otherwise repeat the bottom bead breaking operation.

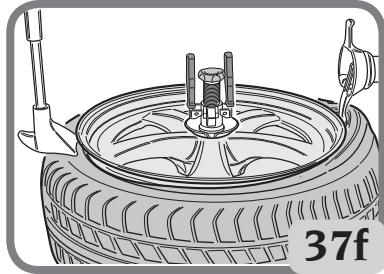

7 - Ensure that the bead at 180° with respect to the tool is in the channel, otherwise use the bead pressing tool to facilitate positioning (Fig. 37f).

8 - Turn the selector  (see Fig. 37g).



9 - Keeping the selector turned , press

the pedal  to turn the turntable and demount the upper part of the tyre from the rim.

If necessary, operate the control  to slightly raise the head and complete top bead removal.

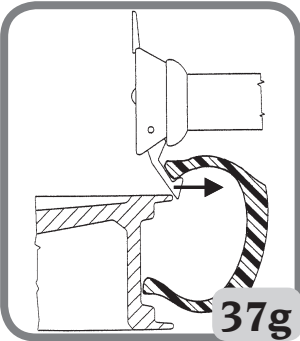

10 - Release the selector  and the pedal 

11 - Withdraw the movable tool from the work area

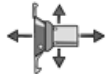

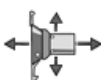
12 - Operate the lever  to move the head to the lower part of the wheel (Fig. 37h).

13 - Manually position the tyre so that the tool hook is between the lower bead and the rim (Fig. 37i).

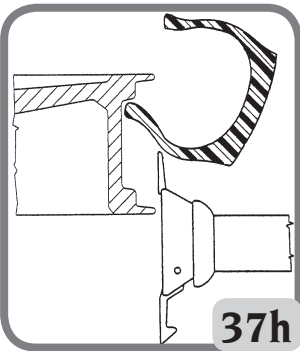

14-Operate the lever

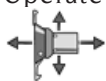

to position the fixed tool at the correct height for removing the second bead (Fig. 37l).

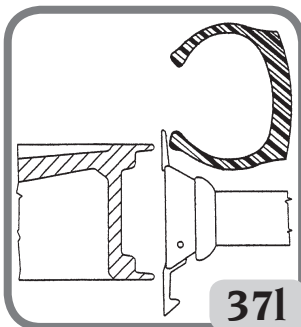
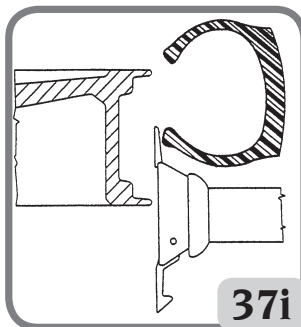

15-Operate the lever



and move the lower bead breaking disc upwards (Fig. 37m - 37n) up to 5 mm above the top edge of the rim.



16-Press the pedal



to turn the turntable and press the **button to activate penetration of the lower bead breaker.**

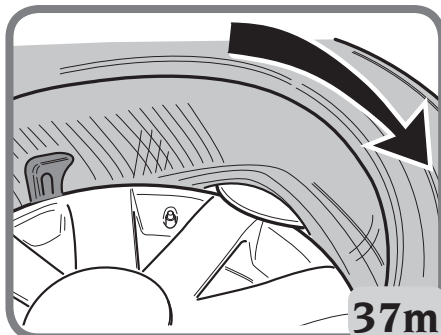

17- If necessary, operate the control to slightly lift the lower bead breaker disc.

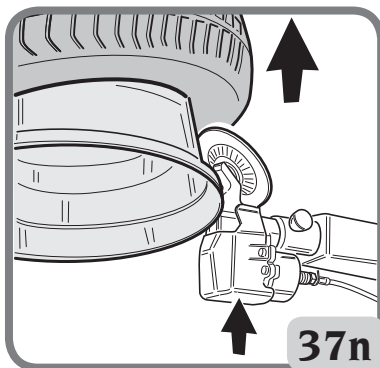

EN

6.10. MOUNTING

CAUTION

Always check that the tyre/rim match-mounting is correct in terms of compatibility (tubeless tyre on tubeless rim; tube type tyre on tube type rim) and geometrical size (keying diameter, cross-section width, off-set and shoulder profile) before mounting.

Also check that rims are not deformed, that their fixing holes have not become oval, that they are not scaled or rusty and that they do not have sharp burrs on the valve holes.

Check that the tyre is in good condition with no signs of damage.

1 - Carefully lubricate the sidewalls of the tyre along the entire circumference of the bottom and top bead (Fig.38).



2 - Operate the control to remove the disc from the work area.

3 - The tool is already positioned at the correct height for assembling the first bead (Fig. 38B). Manually adjust the tyre so that the upper shoulder of the rim passes the lower bead and goes into the channel (Fig. 38a - 38b).

4 - Keep pressed down slightly the section of the tyre with the lower bead not yet inserted in the rim and turn the



turntable

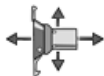

5 - Operate the lever to move the tool head to the upper work area to mount the upper bead.

6 - During movement, press the button



to configure the fixed tool or the mounting phase of the upper bead (Fig. 38c).

7 - Operate the handle P (Fig. 38d) to manually lower the upper bead breaking disc.

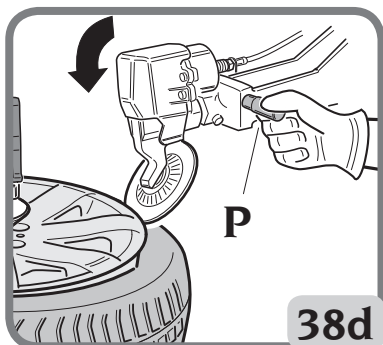
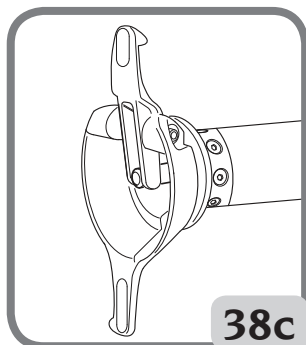
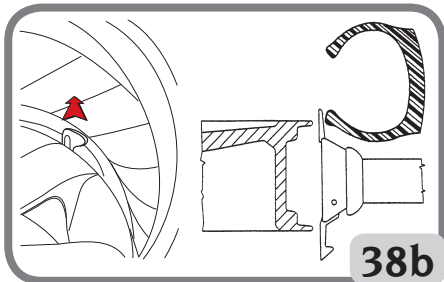
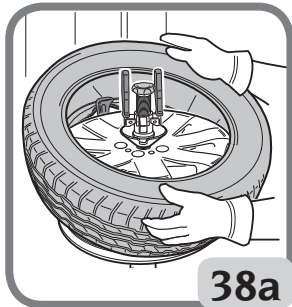
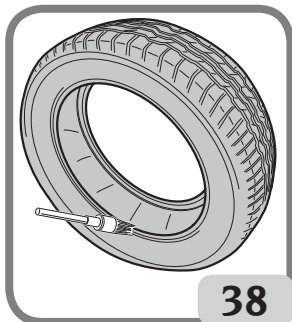

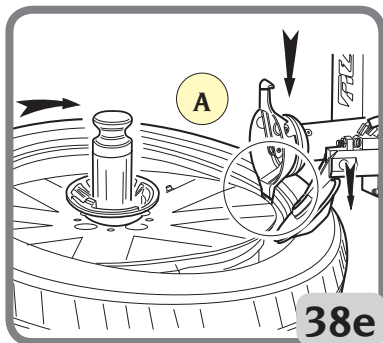

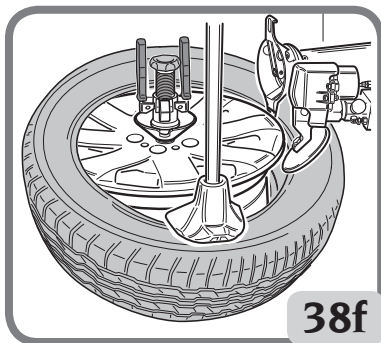

38e

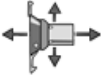

38f

8 - Operate the lever  by lowering the tool and manually adjusting the tyre into position (Fig. 38e).

9 - Push the tyre  under the shoulder level (Fig. 38e).

10- Use the bead pressing tool (Fig. 38f) and, if necessary, bead pressing clamps (Fig. 38g) on the rim shoulder, ensuring that the upper bead is in the channel.

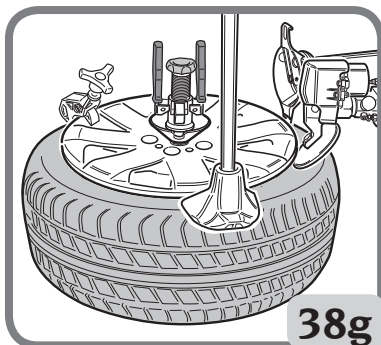

38g

CAUTION

Proceed with caution to prevent any injuries. Ensure that the top bead is correctly loaded on the tool before carrying out mounting (Fig. 38G).

EN



11- Press the pedal  to start rotation until the second bead has been mounted.

CAUTION

Proceed with caution to prevent any injuries. Make sure the top bead is correctly inserted in the rim channel, throughout the entire mounting stage.

12- Remove the bead pressing clamps or the bead pressing tool.



13- Return the bead breakers to the top



and bottom

ends (Fig. 38h).

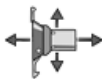
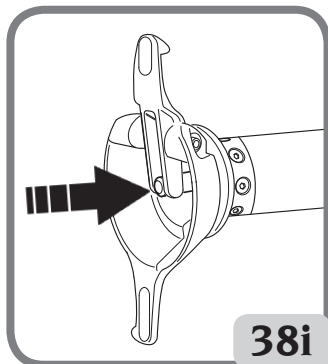
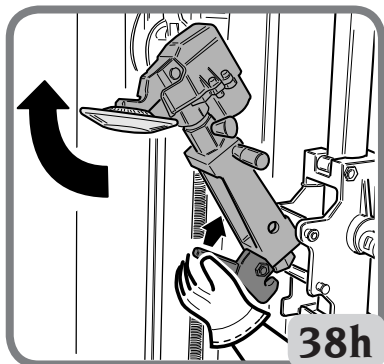

14- Withdraw the fixed tool from the work area (Fig. 38i).

CAUTION

Position the bead pressing tool in the correct rest position so that it does not interfere with the work area.

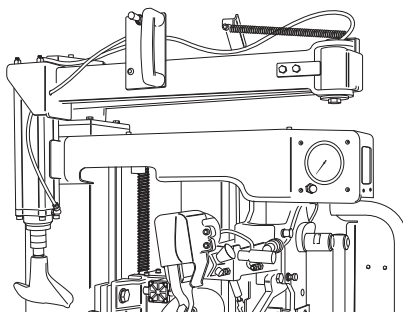

6.11. APPROVED UHP AND RUN FLAT TYRE DEMOUNTING AND MOUNTING PROCEDURE

For this type of tyre please refer to the instructions in the manual prepared by WDK (German Tyre Industry Association).

6.12. TYRE INFLATION

6.12.a. SAFETY REGULATIONS

	<p style="text-align: center;"> DANGER</p> <p>RISK OF EXPLOSION Never exceed the pressure recommended by the tyre manufacturer. Never mount tyres on rims with a different diameter. An exploding tyre can cause personal injury or death.</p>
---	---

Check that both the upper and lower beads and the rim bead seat have been suitably lubricated with paste appropriate for mounting.

Safety goggles with plain lenses and safety footwear must be worn.

Clamp the rim on the turntable during inflation.

Remove the valve core if it has not already been removed.

Connect the inflation line to the valve.

Press the pedal to inflate the tyre and make the beads adhere. Stop frequently to check the internal tyre pressure on the pressure gauge.

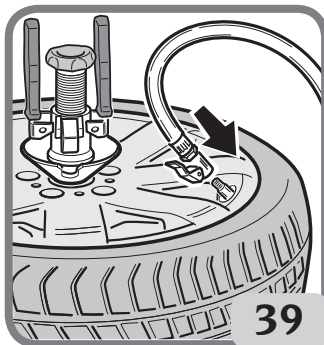

<p style="text-align: center;"> CAUTION</p> <p>Proceed with caution to prevent any injuries. Carefully read, understand and observe the following instructions.</p>	EN
--	-----------

1. Overinflated tyres can explode, producing hazardous flying debris that may result in an accident.
2. Tyres and rims that do not have the same diameter are “mismatched”. Never attempt to mount or inflate any tyre and rim that are mismatched. For example, never mount a 16” tyre on a 16,5” rim (or vice versa). It is very dangerous. Tyres and rims that do not correspond could explode and cause accidents.
3. Never exceed the inflation pressure for the tyre indicated by the manufacturer on the side of the tyre itself.
Carefully check that the air hose is well inserted in the valve.
4. Never bring your head or other body parts close to a tyre during inflation or bead insertion operations.



This machine is not a safety device against the possible risk of explosion of tyres, air chambers or rims.

5. Maintain a suitable distance from the tyre changer while inflating. Do not approach it.

CAUTION



During this operation, noise levels assessed at 85 dB(A) may occur. It is therefore suggested that ear protectors be worn.

DANGER

RISK OF EXPLOSION: The breakage of a pressurised rim or tyre could cause an explosion that projects the wheel to the side or upwards with a force that could cause damage, serious injuries or even death!

Do not mount tyres on rims without first checking the exact correspondence of the dimensions (printed on the rim and tyre) and for the presence of defects or damage.

This tyre changer is NOT a safety device and does not eliminate risks and damage from a possible explosion. Do not permit other people to approach the work area.

6.12.b. TYRE INFLATION

1. Make sure the wheel is securely clamped on the turntable by means of the centring handle (Fig. 40).
2. Make sure that the tool head, the upper and lower bead breaking units and the bead pressing tools are not near the work area and, if possible, are in the rest position (see Fig. 40a).
3. Remove the valve core if it has not already been removed (Fig. 40b).

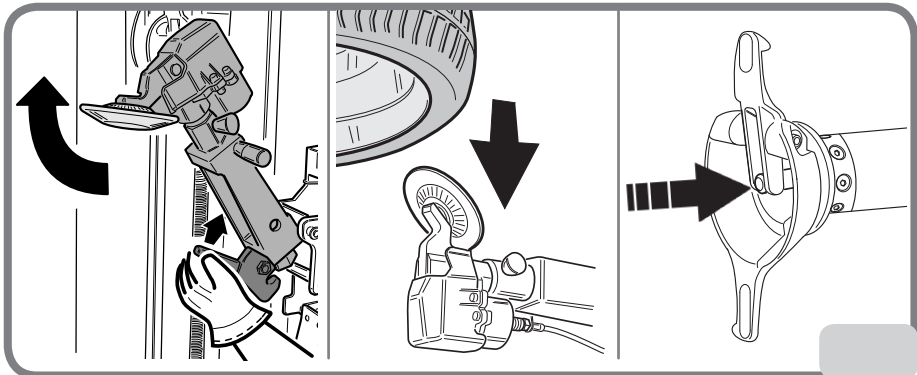
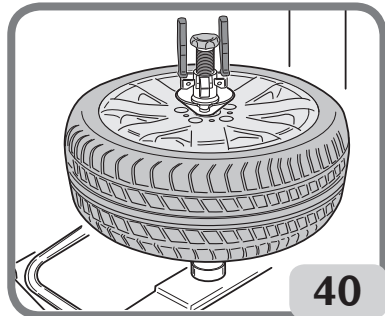

4. Connect the Doyfe connector of the inflating hose to the valve stem (Fig. 40c).



5. Press the pedal  to inflate the tyre at short intervals. Frequently check the pressure on the pressure gauge (1, Fig.40d) to make sure that the pressure NEVER exceeds the maximum pressure indicated by the manufacturer on the tyre. The tyre widens and the beads are positioned.

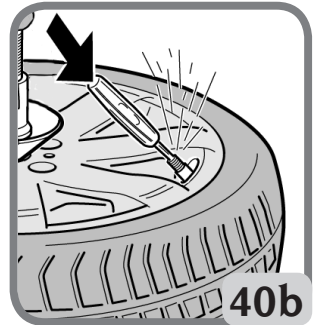

If necessary:

6. Continue with inflation to the maximum value of 3.5 bar to correctly position the tyre on the rim. Avoid distractions during this operation, and continually check tyre pressure on the air pressure gauge (1, Fig. 40d) to prevent excessive inflation. Inflating tubeless tyres requires a higher air flow rate to allow the beads to overcome the HUMP rim - see types of rim profiles for mounting without an air chamber in Fig.40e

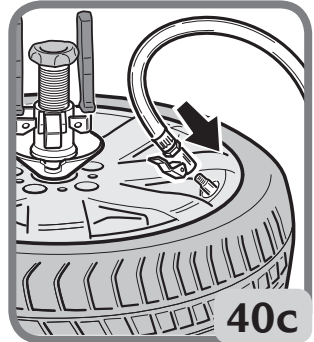

7. Check that the beads are correctly inserted in the rim; otherwise, deflate the tyre, break the beads as described in the relevant section, lubricate and turn the tyre on the rim. Repeat the mounting operation described previously and check again.

8. Reinsert the internal valve mechanism.

9. Bring the pressure to the operating value by pressing the inflation button (2, Fig. 40d).

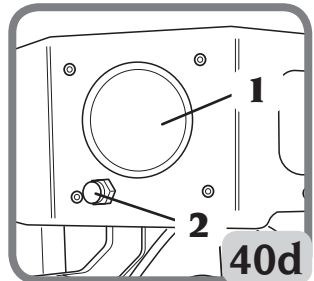

10. Place the cap back on the valve.

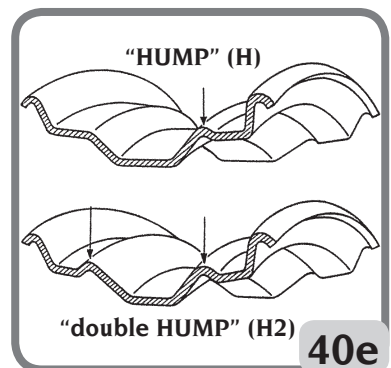

EN

6.12.c. SPECIAL PROCEDURE (TI VERSION)

CAUTION

Before starting with the operations described below, make sure there is no dirt, dust or other impurities near the inflation nozzles.

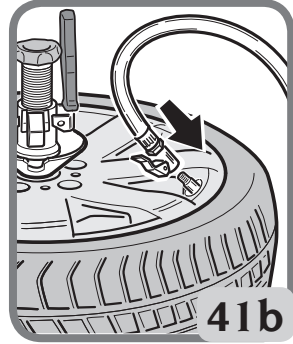
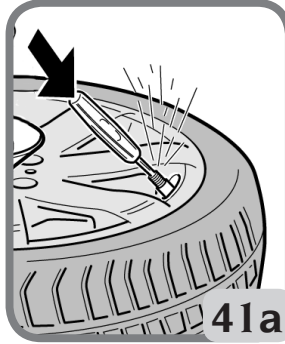
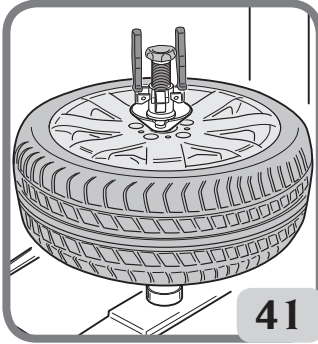

If while inflating the tyre is not positioned correctly on the rim due to excessive space between the tyre and the rim, a jet of pressurised air can be used with the clamps of the T.I. accessory (quick bead insertion) (optional). Verify that both upper and lower tyre beads and rim bead seat have been properly lubricated with an approved assembly paste.

1. Make sure that the rim is correctly clamped on the turntable (Fig. 41).
2. Remove the valve core if it has not already been removed (Fig. 41a).

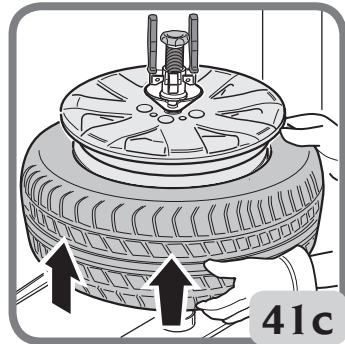

3. Connect the Doyfe connector of the inflating hose to the valve stem (Fig. 41b).

4. Pull the tyre up slightly in order to reduce the space between the upper bead and the rim (Fig. 41c).



5. Fully press down on the inflation pedal and at the same time, press the 2 buttons on the accessory to emit a jet of high pressure air from the four jets, which make it easier to position the tyre beads (Fig. 41d).

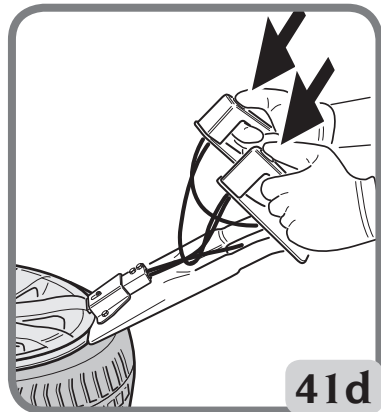

CAUTION

To increase the effectiveness of the air jets, manually lubricate and lift the lower bead before activating the nozzles

CAUTION

To improve the operation of the tubeless tyre inflation system the line pressure must be between 8 and 10 bar.

Continue inflating the tyre using the air hose. Frequently stop inflation and check the pressure on the pressure gauge.



CAUTION

Risk of explosion. During the bead insertion phase, do not exceed the maximum pressure indicated by the manufacturer on the sidewall of the tyre.

Once the bead has been inserted, refit the internal part of the valve and then inflate the tyre to the pressure indicated by the vehicle manufacturer.



CAUTION

Operate the inflation jets only for tyre bead insertion. Do not point jets towards people.

Discharge the air from the pneumatic system before disconnecting the power supply or other pneumatic components. The air is accumulated in the tank for operating the bead insertion jets.



CAUTION

Operate the air jets only after making sure that the device is securely in position and the rim is correctly blocked.



CAUTION

RISK OF EXPLOSION. Do not mount a tyre and a rim that do not have the same diameter (e.g., 16 and 1/2 inch tyre and a 16 inch rim).

If the tyre is excessively inflated, the air can be released by pressing the brass manual deflation button located below the air pressure gauge ("2" - Fig.41e)

Disconnect inflation hose from valve rod.

6.13 UNCLAMPING AND UNLOADING THE WHEEL

6.13.a. WHEEL UNCLAMPING

- Loosen the device by turning the handles anticlockwise (Fig. 42).
- Press the retainers "1" and move the centring cone away from the rim manually (Fig. 42a).
- Turn the locking system anticlockwise to release it from the turntable (Fig. 42b).
- Remove the device from the rim (Fig. 42c).

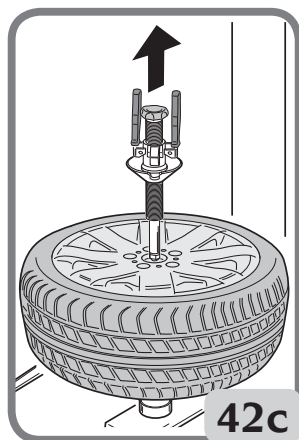
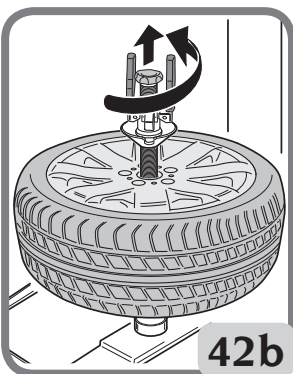
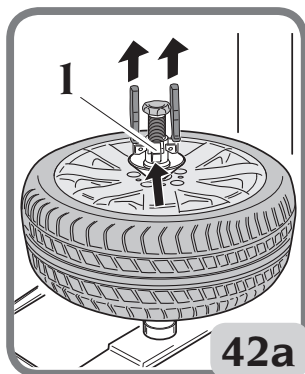
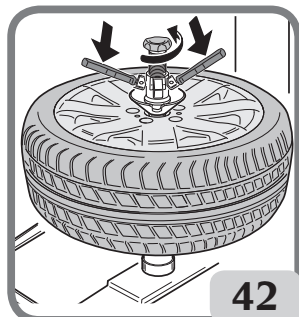
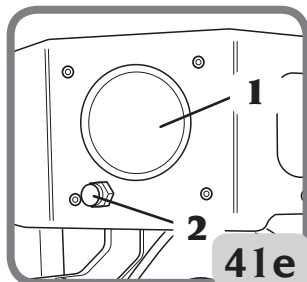

WHEEL UNCLAMPING ("AUTOMATIC" VERSION)

- Press pedal (3, Fig. 43) to unlock the wheel from the turntable.

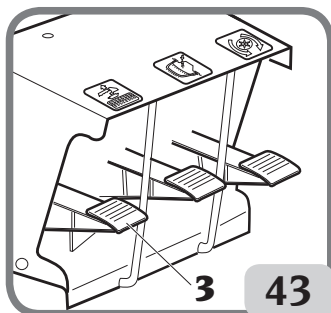

- Remove the locking handle (1, Fig. 43a) from the wheel.

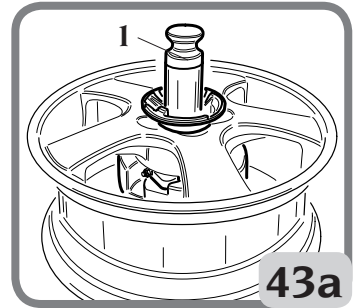

6.13.b WHEEL UNLOADING

Press the “DOWN” pedal to operate the lifter and unload the wheel.

NOTE: When the wheel is being lifted or lowered, an acoustic signal alerts the user about the operation in progress.

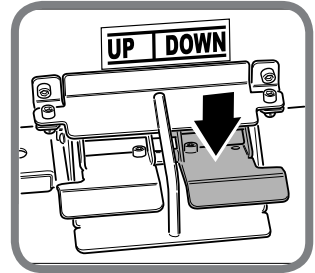

7. TROUBLESHOOTING

If there is a power interruption while the dismantling/mounting tool is in the position between the rim and tyre, proceed as follows:

- Restart the machine **without resetting it**.
- Using the bead breakers with a vertical movement, create space for the mounting/demounting tool in order to release it from the tyre.

EN

7.1 LIST OF DISPLAY SIGNALS

- “E1” : **X AXIS LIMITATION SIGNAL.**
THIS APPEARS WHEN THE CURRENT ABSORPTION OF THE LINEAR ACTUATOR IS TOO HIGH.
The signal disappears when the control is inverted
- “E2” : **Y AXIS LIMITATION SIGNAL.**
THIS APPEARS WHEN THE CURRENT ABSORPTION OF THE MOTOR THAT PERMITS VERTICAL HEAD MOVEMENT IS TOO HIGH.
The signal disappears when the control is inverted
- “E3” : **GENERAL LOWER POWER SIGNAL FOR THE MACHINE.**
THIS APPEARS WHEN THE MAINS VOLTAGE IS INSUFFICIENT FOR CORRECT MACHINE OPERATION.
Turn off the machine and check the mains voltage

“TOE”: “ENCODER TIME-OUT” SIGNAL.
THIS APPEARS WHEN THE CARD DOES NOT RECEIVE SIGNALS FROM THE ENCODER FOR TWO SECONDS AFTER RESETTING TO 28 INCHES.
It may be necessary to replace the actuator, the card or the encoder cable

“ENC”: “ENCODER” SIGNAL.
THIS APPEARS WHEN THE CARD DOES NOT RECEIVE SIGNALS FROM THE ENCODER DURING THE PHASE OF RESETTING TO 28 INCHES.
It may be necessary to replace the actuator, the card or the encoder cable

IN THE CASE OF “TOE” AND “ENC” THE MACHINE SWITCHES TO MANUAL MODE, MAKING IT POSSIBLE TO MOVE THE WHEEL SUPPORT ONLY WHEN PRESSING THE UP OR DOWN BUTTON

It may be necessary to replace the actuator, the card or the encoder cable

“EFC”: “LIMIT SWITCH ERROR” SIGNAL:
THIS APPEARS WHEN THE X AND Y AXIS LIMIT MICROSWITCHES DO NOT WORK.
Check the connection of the limit microswitches and if one of them is broken

“ROT”: INCORRECT ROTATION DIRECTION SIGNAL:
THIS APPEARS WHEN THE ENCODER CHANNELS ARE CONNECTED INCORRECTLY, INVERT THE CONNECTIONS.
Invert the poles of the encoder power supply cable

CAUTION

Risk of injury or death

The “Spare parts” handbook does not authorise the user to carry out work on the machine with the exception of those operations explicitly described in the User Manual. It only enables the user to provide the technical assistance service with precise information, to minimise delays.

8. MAINTENANCE

DANGER

When the machine is disconnected from the air supply, the devices bearing the sign shown above may remain pressurised.



CAUTION

The “Spare parts” handbook does not authorise the user to carry out work on the machine with the exception of those operations explicitly described in the User Manual. It only enables the user to provide the technical assistance service with precise information, to minimise delays.

CAUTION

Do not remove or change any part of the machine (except for maintenance purposes).

CAUTION

It is prohibited to perform any operation that changes the pre-set value of the pressure regulation valve or pressure limiter. The manufacturer declines all liability for damage resulting from tampering with these valves.

CAUTION

Before making any change or performing maintenance, disconnect the machine's power and air supplies and ensure that all moving parts are suitably blocked.

WARNING

Keep the work area clean. Do not use compressed air, jets of water or thinner to remove dirt or residues from the machine. While cleaning, try as far as possible to prevent dust from forming or rising.

CAUTION

CORGHI declines all liability for claims derived from the use of non-original spare parts or accessories.

EN

Scheduled maintenance:

CAUTION

The machine will periodically prompt maintenance reminders. Failure to observe instructions could affect the proper operation of the machine.

- Make sure the condensate is draining from the filter-regulator unit:

The filter-regulator unit is equipped with a semi-automatic device for condensate draining. This device is automatically activated whenever pneumatic supply to the machine is cut off. Drain the condensate manually (1, Fig. 44) when the level rises above level 2, Fig. 44.

To be carried out every month.

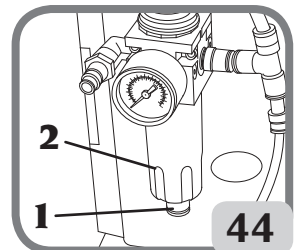

- **Clean and lubricate the tool head carriage guide (1, Fig.45):**

Clean with environmentally-friendly solvents and lubricate with LIPLEX EP 2 lubricant or equivalent.
To be carried out every two months.

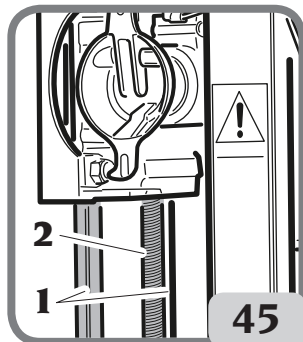

- **Lubricate the tool head unit translation screw (2, Fig.45):**

Clean with environmentally-friendly solvents and lubricate with MOLYguard lube PTFE ISO 68 oil or equivalent.
To be carried out every three months.

- **Clean and lubricate the bead breaker sliding panel (3, Fig.46):**

Clean with environmentally-friendly solvents and lubricate with ROLOIL SUPER LUBRICANT PTFE synthetic gel or equivalent.
To be carried out every two months.

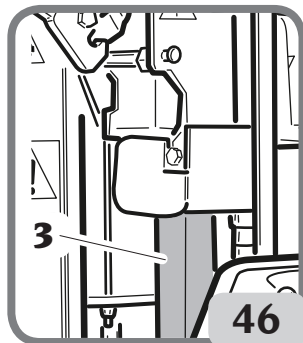

- **Check the condition of the tool carriage stop pads (4-5, Fig. 47):**

No breakage or permanent deformation must be present.
Otherwise, contact technical assistance.
To be carried out every six months.

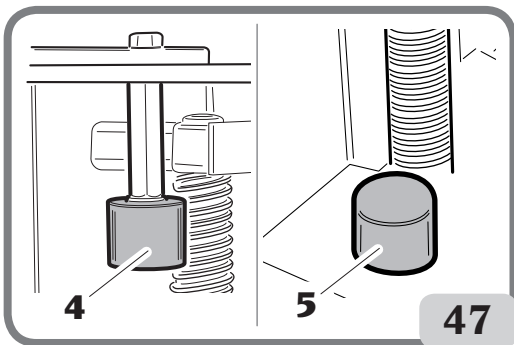

- **Check the condition of the rubber guards on the bead breakers (6, Fig. 48):**

The guards must be present, with no breakage or evident permanent deformation.
Otherwise, contact technical assistance.
To be carried out every three months.

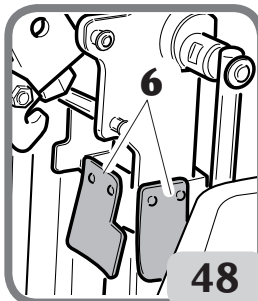

- **Clean and lubricate the lower bead breaking unit pin (7, Fig. 49) and connection pin (8, Fig. 49):**

Clean with environmentally-friendly solvents and lubricate with ordinary grease.
To be carried out every month.

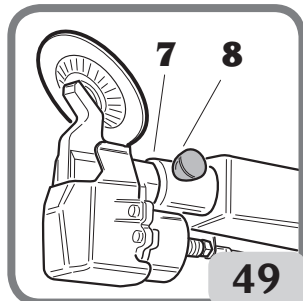

- **Contact the service network to check the belts and rubber pads:**

Periodic check by the service network.
To be carried out every 7000 wheels.

- Clean the top of the turntable (Fig 50):

Remove accumulated dirt and clean with environmentally friendly solvents.
To be performed weekly

- General machine check, contact the service network:

General periodic check by the service network.
To be carried out every year.

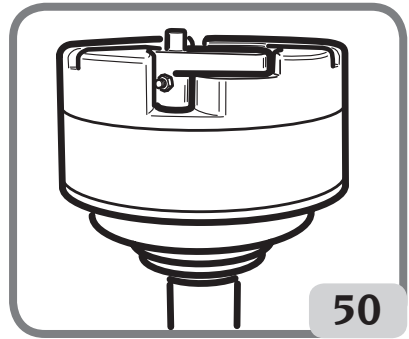

9. INFORMATION ABOUT DEMOLITION

If the equipment is to be scrapped, sort all electrical, electronic, iron and plastic components. Dispose of the components separately in compliance with local regulations.

10. ENVIRONMENTAL INFORMATION

The disposal procedure described below only applies to equipment with the barred bin



symbol on the rating plate 

This product may contain substances that are potentially harmful to the environment and human health unless disposed of properly.

The information provided below is intended to prevent these substances from being released into the environment, and to improve the use of natural resources.

Electrical and electronic equipment must never be disposed of in the usual municipal waste but must be separately collected for proper treatment. The barred bin symbol affixed on the product and shown in this page is meant to remind users that the product must be disposed of properly at the end of its life cycle.

This prevents the inappropriate disposal of the substances contained in this product, or the improper use of parts of this product, and the resulting hazards for the environment and human health. It also helps to ensure that many materials contained in this product are recovered, recycled and reused.

To this end, manufacturers and dealers of electrical and electronic equipment maintain special systems for the collection and disposal of such equipment.

At the end of the product life cycle, contact your dealer for information about disposal procedures. Upon purchase, purchasers are offered the opportunity to return their end-of-life equipment to dealer free of charge, provided that the equipment is of the same type and served the same purpose as the newly-purchased product.

Anyone disposing of the product otherwise than as described above will be liable to prosecution under the laws of the country where the product is disposed of.

We also urge you to adopt other environmental-friendly practices: recycle the internal and external packing materials which come with the product and dispose of spent batteries (installed in the product) properly.

With your help, we can reduce the amount of natural resources used to produce electrical and electronic equipment, minimise the use of landfills to dispose of old products, and improve quality of life by preventing the discharge of potentially hazardous substances into the environment.

11. INFORMATION AND WARNINGS ABOUT OIL

Disposal of waste oil

Never pour waste oil in sewers, storm drains, rivers or streams; collect and deliver it to companies authorised to collect it.

Oil spills or leaks

Contain spillages using soil, sand or other absorbent material.

Degrease the contaminated area with solvents, taking care to disperse the fumes. The residual cleaning material must be disposed of as prescribed by law.

Precautions for the use of oil

- Avoid contact with skin.
- Avoid formation and spreading of oil mists into the atmosphere.
- Adopt the following simple sanitary precautions:
 - protect against oil splashes (appropriate clothing, protective guards on machines);
 - wash frequently with soap and water; do not use cleaners or solvents that can irritate your skin or remove its natural protective oil;
 - do not dry hands with dirty or greasy rags;
 - change clothing if impregnated with oil, and in any case at the end of each work shift;
 - do not smoke or eat with greasy hands.
- Also use the following preventive and protective equipment:
 - gloves resistant to mineral oils, with lining;
 - goggles, in case of splashes;
 - aprons resistant to mineral oils;
 - screens to protect against oil splashes.

Mineral oil: first aid instructions

- Ingestion: seek medical attention immediately and provide all characteristics of the type of oil ingested.
- Inhalation: for exposure to high concentrations of fumes or oil mist, move the affected person to the open air and seek medical attention immediately.
- Eyes: bathe with plenty of running water and seek medical attention immediately.
- Skin: wash with soap and water.

12. INFORMATION AND WARNINGS ABOUT TYRE LUBRICATING FLUID

Disposal of waste oil

Do not dispose of used lubricant fluids in sewers, storm drains, rivers or streams; collect it and consign it to an authorised disposal company.

Lubricant fluid leaks or spills

Avoid product leaks from spreading by using non-inflammable absorbent materials such as dirt, sand, vermiculite or diatomaceous earth.

Clean the contaminated area preferably with a detergent, do not use solvents.

Precautions for the use of lubricant fluid for tyres

- Avoid splashes or contact with the skin.
- Avoid splashes or contact with eyes.
- Do not inhale the fumes.
- Adopt the following simple sanitary precautions:
 - protect skin and eyes against lubricating fluid splashes (appropriate gloves, goggles);
 - in case of contact with skin, wash immediately with plenty of water;
 - in case of contact with eyes, rinse immediately with plenty of water and seek medical advice;
 - if swallowed, seek medical advice and show the label;
 - do not dry hands with dirty rags;
 - change your clothes if they are soaked in lubricating fluid;
 - do not smoke or eat with hands soiled with lubricating fluid.

13. FIREFIGHTING EQUIPMENT TO BE USED

Refer to the table below to choose the most suitable fire extinguisher:

	Dry materials	Inflammable liquids	Electrical equipment
Water	YES	NO	NO
Foam	YES	YES	NO
Dry chemical	YES*	YES	YES
CO ₂	YES*	YES	YES
YES*	<i>Use only if more appropriate extinguishers are not at hand or when the fire is small.</i>		



WARNING

This table contains general instructions to be used as guidelines for users. Contact the manufacturer for details of the applications of each type of extinguisher.

EN

14. GLOSSARY

Tyre

A tyre consists of: **I-the tyre**, **II- the rim** (wheel), **III-the air chamber** (in tube type tyres), **IV-pressurised air**.

The tyre must:

- withstand a load,
- ensure driving power,
- steer the vehicle,
- aid handling and braking,
- aid vehicle suspension.

I - Tyre The tyre is the main part of the unit that is in contact with the road and is therefore designed to support the internal air pressure and all other stress arising from use.

The tyre section shows the various parts it consists of:

1 - *The tread*. It is the part in contact with the road while the tyre is rolling. It comprises a rubber compound and a "pattern" suitable for ensuring good resistance to abrasion and good grip in dry and wet conditions, as well as quiet operating conditions.

2 - *Edge or bracing*. This is a metal fabric or textile insert, in the area of the outer bead part. It protects the casing ply from rubbing against the rim.

3 - *Casing*. This is the resistant structure and comprises one or more layers of rubber plies. The way the plies comprising the casing are arranged give the structure its name. The following structures are possible:

Conventional: the plies are inclined and arranged so that the strands comprising a ply overlap with those of the adjacent ply. The tread, which is the part of the tyre in contact with the ground, is part of the sidewalls and so during rolling, sidewall flexure is transmitted to the tread.

Radial The casing consists of one or more plies with the cords in a radial direction.

A radial casing in itself is quite unstable. To make it stable and prevent incorrect tread movement in the area of contact with the ground, the casing and the shim under the tread are reinforced with an annular

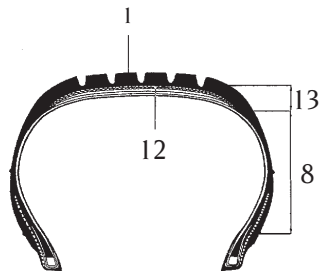
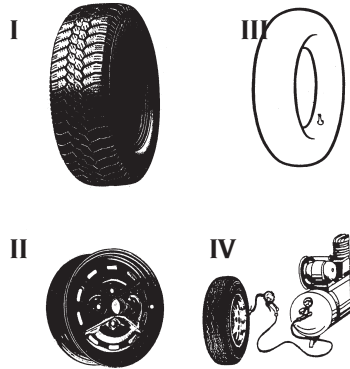

structure, usually called a belt. The tread and sidewall work with different, independent rigidities, so during rolling, sidewall flexure is not transmitted to the tread.

4 - *Side ring* This is a metal ring with various steel wires. The casing plies are secured to the side ring.
 5 - *Belt*. This is a non-flexible circumferential structure comprising cross-ply at very low angles, positioned below the tread, to stabilise the casing in the footprint area.

6 - *Centring band*. This is a small mark that indicates the circumference of the upper part of the bead and is used as a reference to control correct tyre centring on the rim after mounting.

7 - *Protective band*. This is a circumferential marking in the area of the sidewall which is more exposed to accidental rubbing.

8 - *Sidewall*. This is the area between the shoulder and the centring band. It consists of a more or less thin layer of rubber, which protects the casing plies from lateral impact.

9 - *Liner* This is a vulcanised, compound layer, impermeable to air, inside tubeless tyres.

10 - *Filling* This is a generally triangular rubber profile, above the side ring; it provides rigidity for the bead and gradually offsets the abrupt uneven thickness caused by the side ring.

11 - *Flap*. This is the part of the casing ply around the side ring and placed against the casing, to secure the ply and prevent it from slipping.

12 - *Foot*. This is the innermost layer of the tread in contact with the belt, or if the latter is not present (conventional tyres) with the last casing ply.

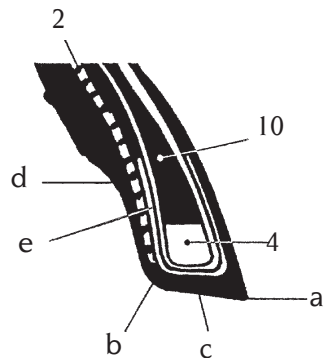
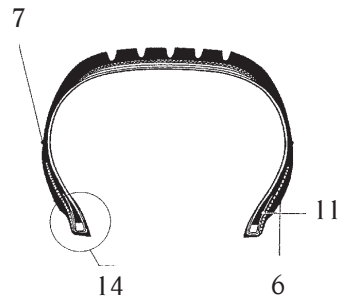
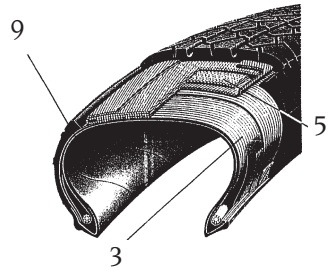

13 - *Shoulder* This is the most external part of the tread, located between the corner and the start of the sidewall.

14 - *Bead*. This is the part that joins the tyre to the rim. The bead point (a) is the inner corner. The spur (b) is the inner part of the bead. The base (c) is the area resting against the rim. The groove (d) is the concave part against which the rim shoulder rests.

Tube type tyres. As a tyre has to contain pressurised air for a long period of time, an air chamber is used. The valve for inserting, maintaining, controlling and restoring pressurised air is, in this case, part of the chamber.

Tubeless tyres. Tubeless tyres consist of a tyre with inner sidewall lined with a thin layer of special impermeable rubber, called a *liner*. This liner helps to maintain air pressure in the casing. This type of tyres must be mounted on specific rims, on which the valve is fixed directly.

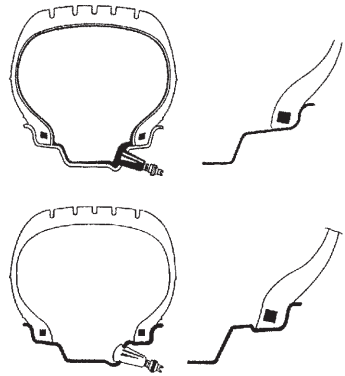

II - Rim (Wheel). The rim is the rigid metal part which connects the vehicle hub to the tyre, on a fixed but non-permanent basis.

Rim profile. The rim profile is the shape of the section in contact with the tyre. It is made with different geometric shapes that serve to ensure: easy assembly of the tyre (inserting the bead into the channel); safety on the move, in terms of anchoring the bead in its seat.

When observing a section of the rim, it is possible to identify different parts that compose it: a) rim width – b) shoulder height – c) tubeless anchoring (HUMP) – d) valve hole – e) ventilation opening – f) offset – g) central hole diameter – h) connection hole centre to centre distance i) keying diameter – j) rim channel.

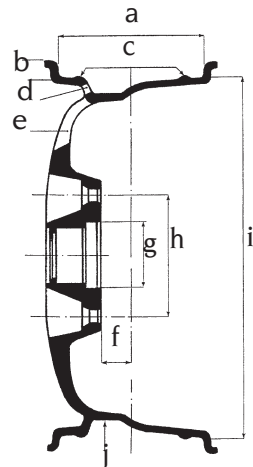

III - Air chamber (tube type tyres). The air chamber is a closed ring-like rubber structure with a valve, which contains pressurised air.

Valve. The valve is a mechanical device to inflate/deflate the tyre and maintain air pressure inside the air chamber (or tyre in the case of tubeless tyres). It consists of three parts: the valve closing cap (a) (to protect the internal mechanism from dust and guarantee air tightness), an internal mechanism (b) and the base (c) (the outer lining).

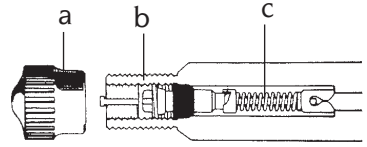

Tubeless Inflater. An inflation system which simplifies inflating tubeless tyres.

Bead insertion. Operation which takes place during inflation and ensures perfect centring between the bead and the rim edge.

Bead pressing clamp. A tool intended for use when mounting the top bead. It is positioned so that it engages the shoulder of the rim and maintains the upper tyre bead inside the well. It is generally used for mounting low profile tyres.

Discharge regulator. Union allowing regulation of the air flow.

Bead breaking. Operation used to detach the bead from the rim edge.

TABLE FOR USING CENTRING AND CLAMPING ACCESSORIES ACCORDING TO RIM TYPE

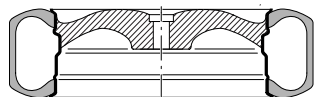

A

Standard rim

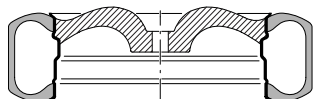

B

Rim with embedded hole

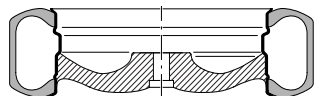

C

Reverse rims

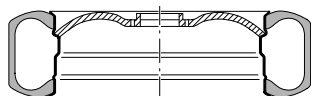

D

Rim for vans

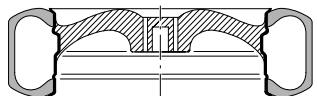

E

Rim without central hole

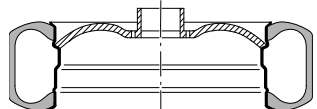

F

Rim with central hole

FIXING ACCESSORIES

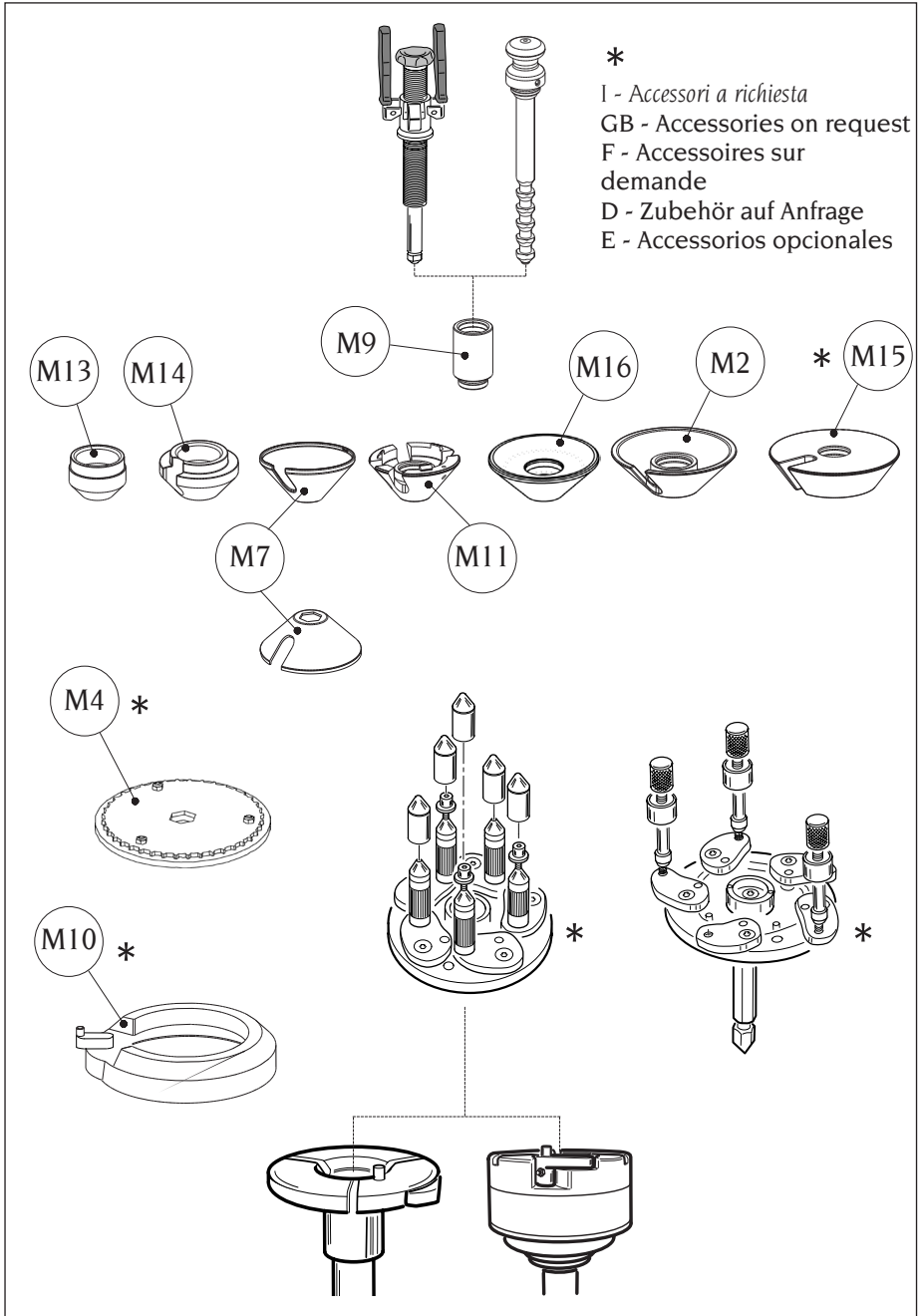

*

I - Accessori a richiesta
 GB - Accessories on request
 F - Accessoires sur demande
 D - Zubehör auf Anfrage
 E - Accesorios opcionales

EN

STANDARD RIM

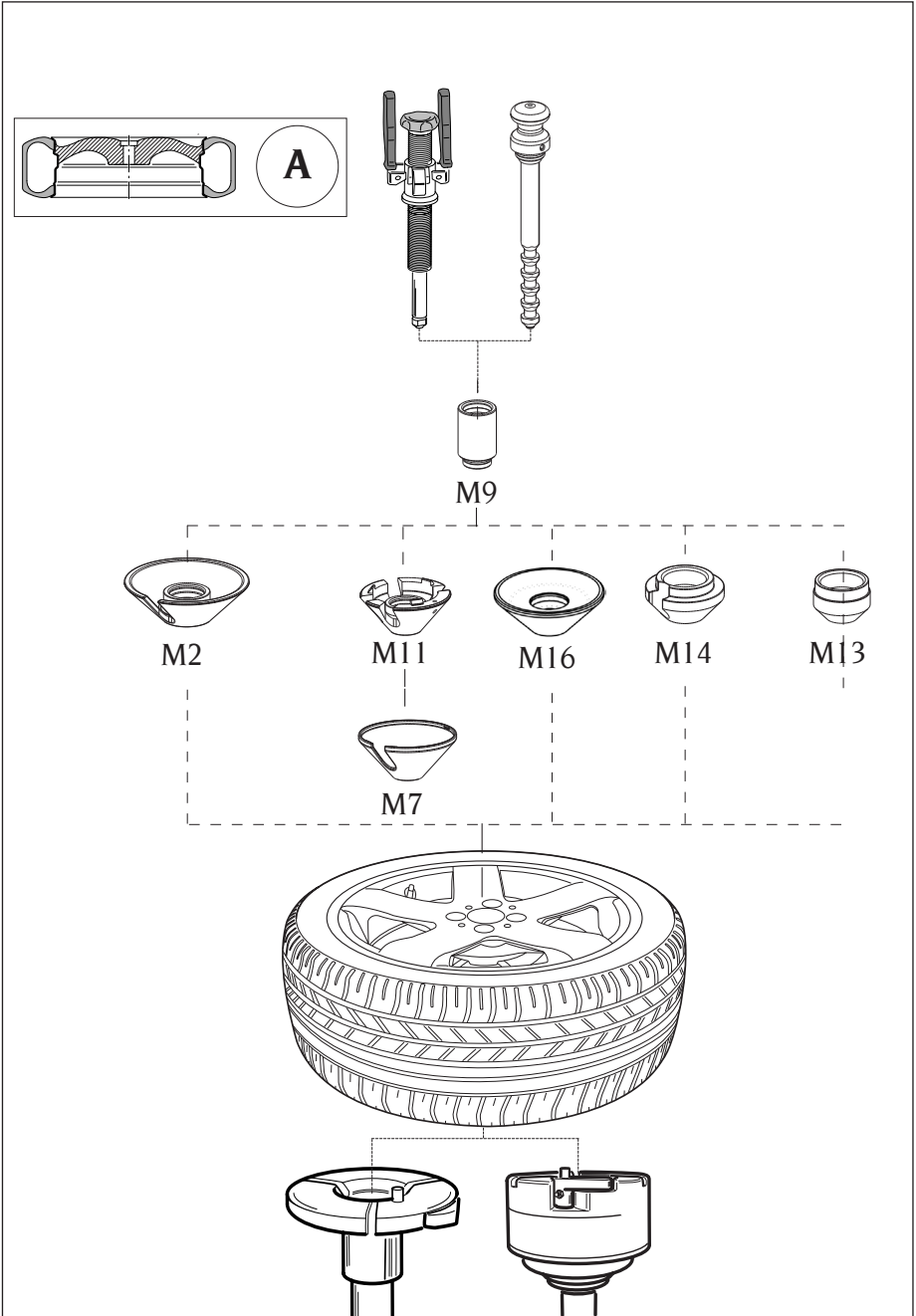

RIM WITH EMBEDDED HOLE

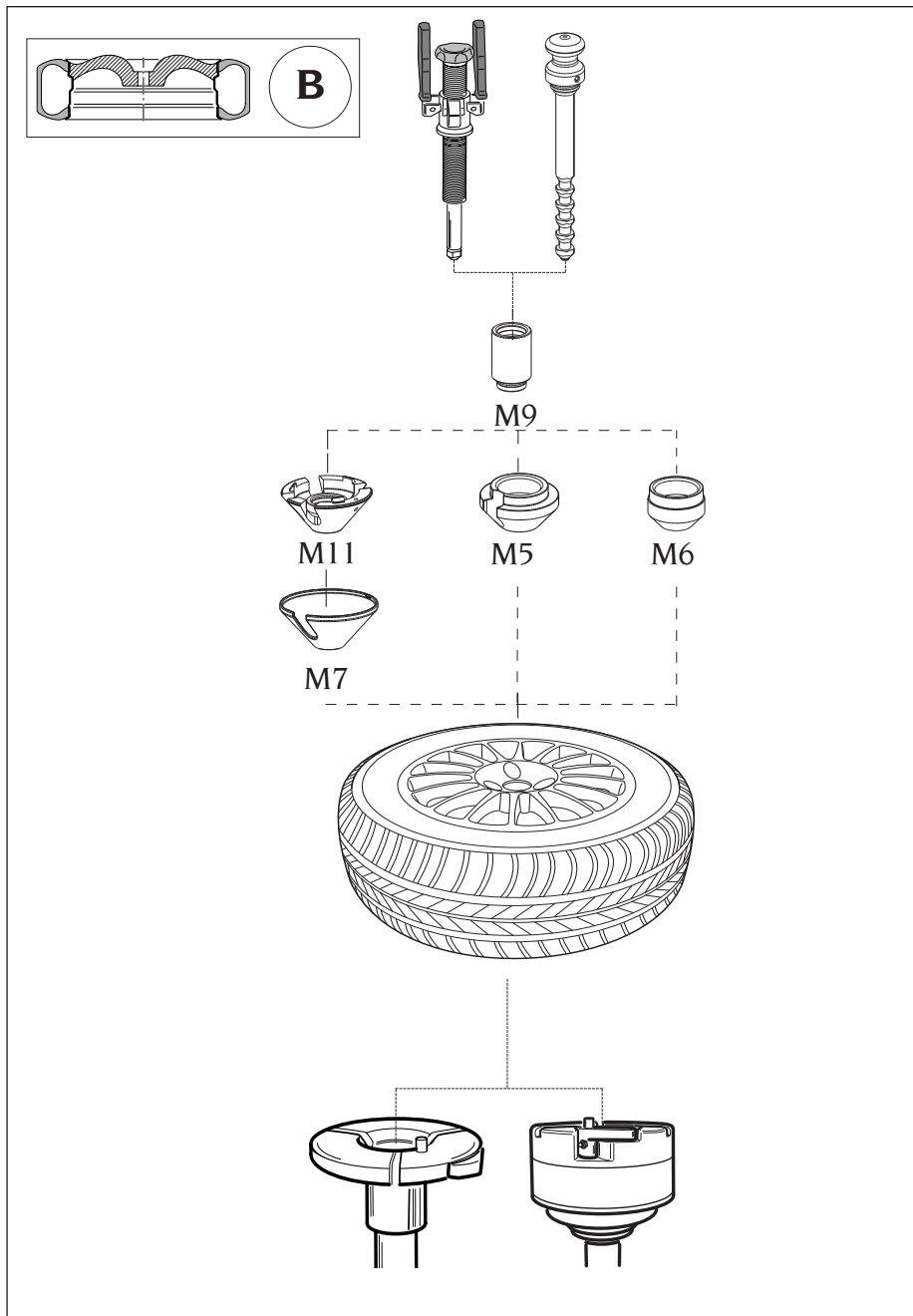

EN

REVERSE RIM

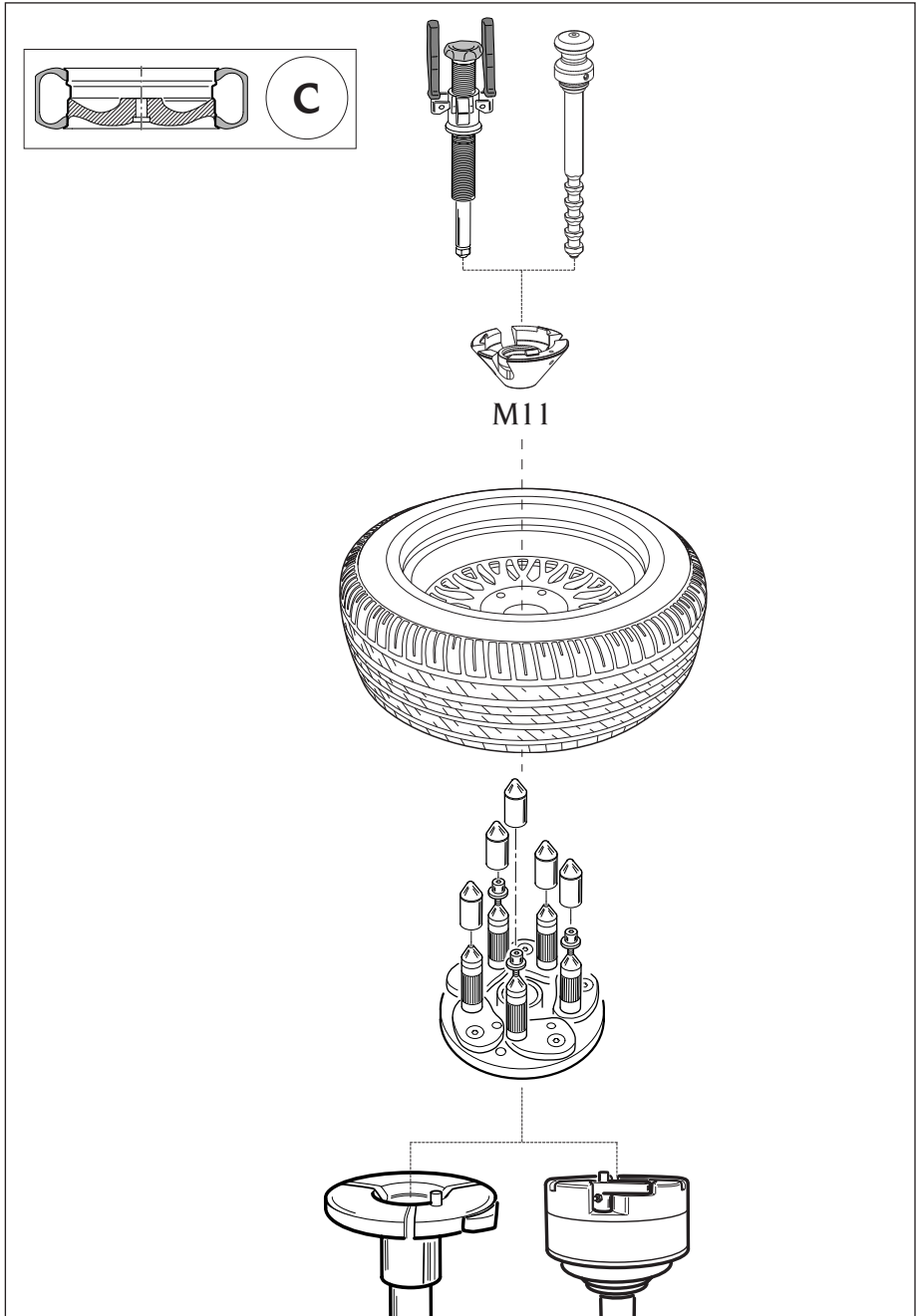

RIM FOR VANS

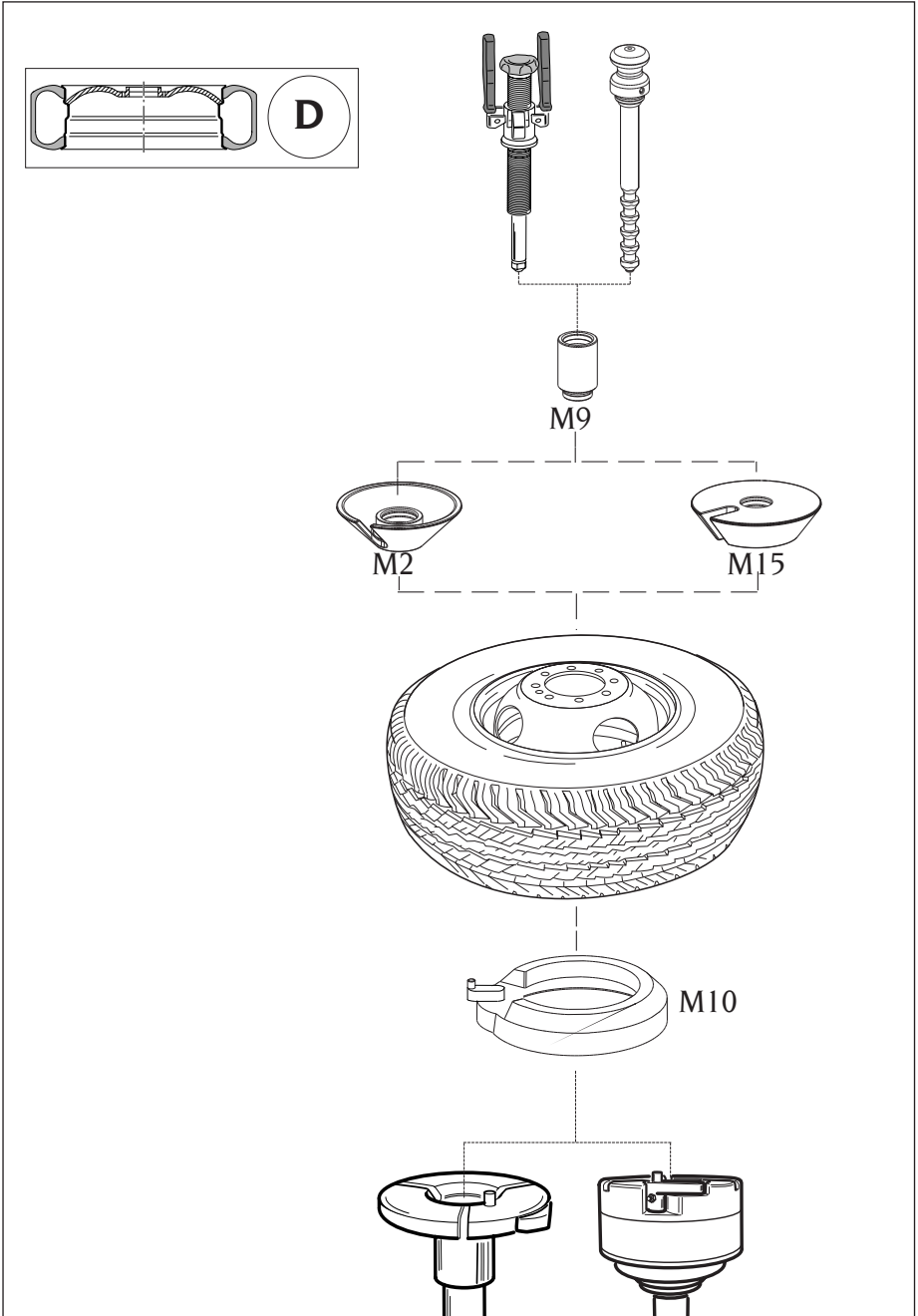

EN

RIM WITHOUT CENTRAL HOLE

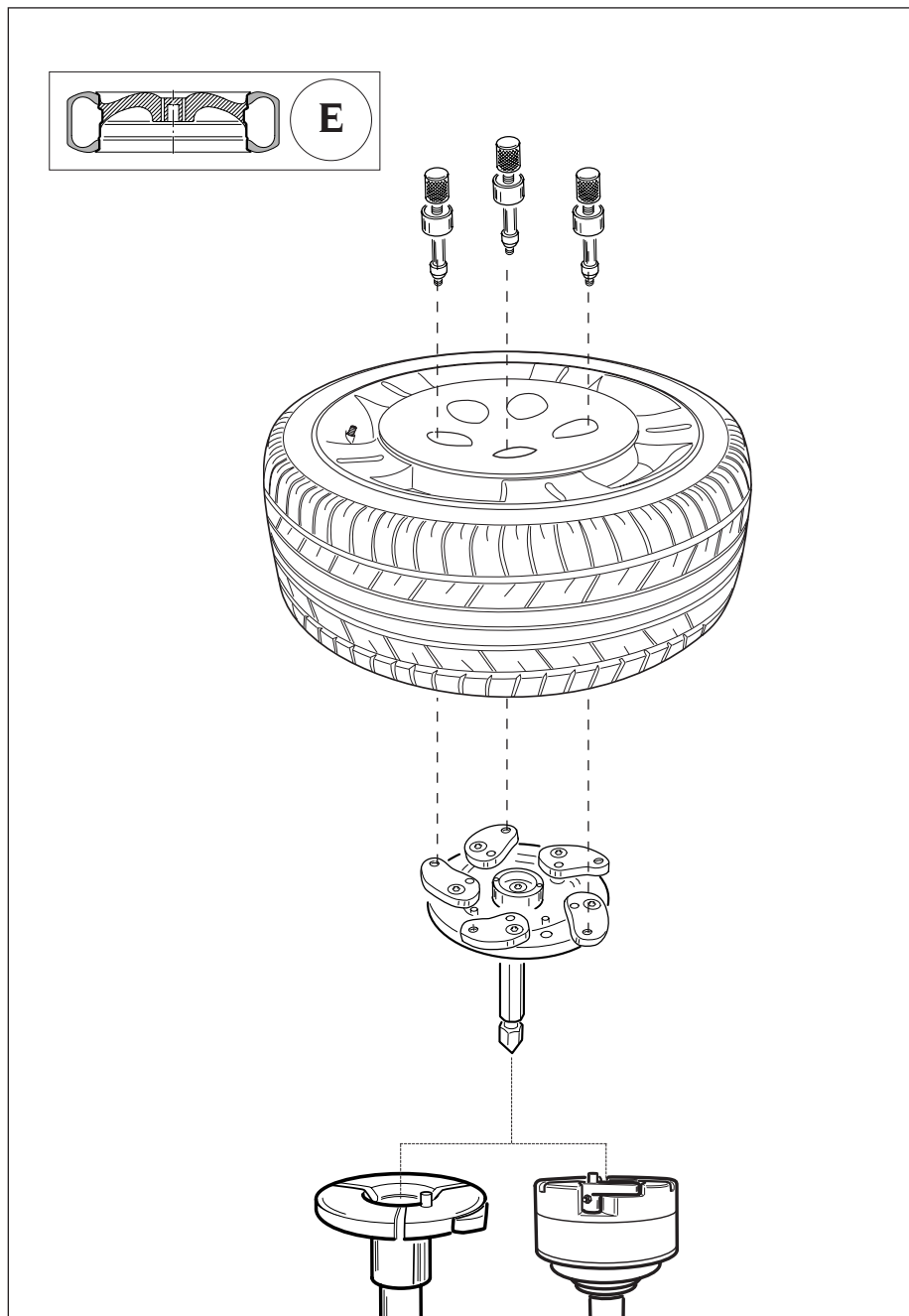

RIM WITH CENTRAL HOLE

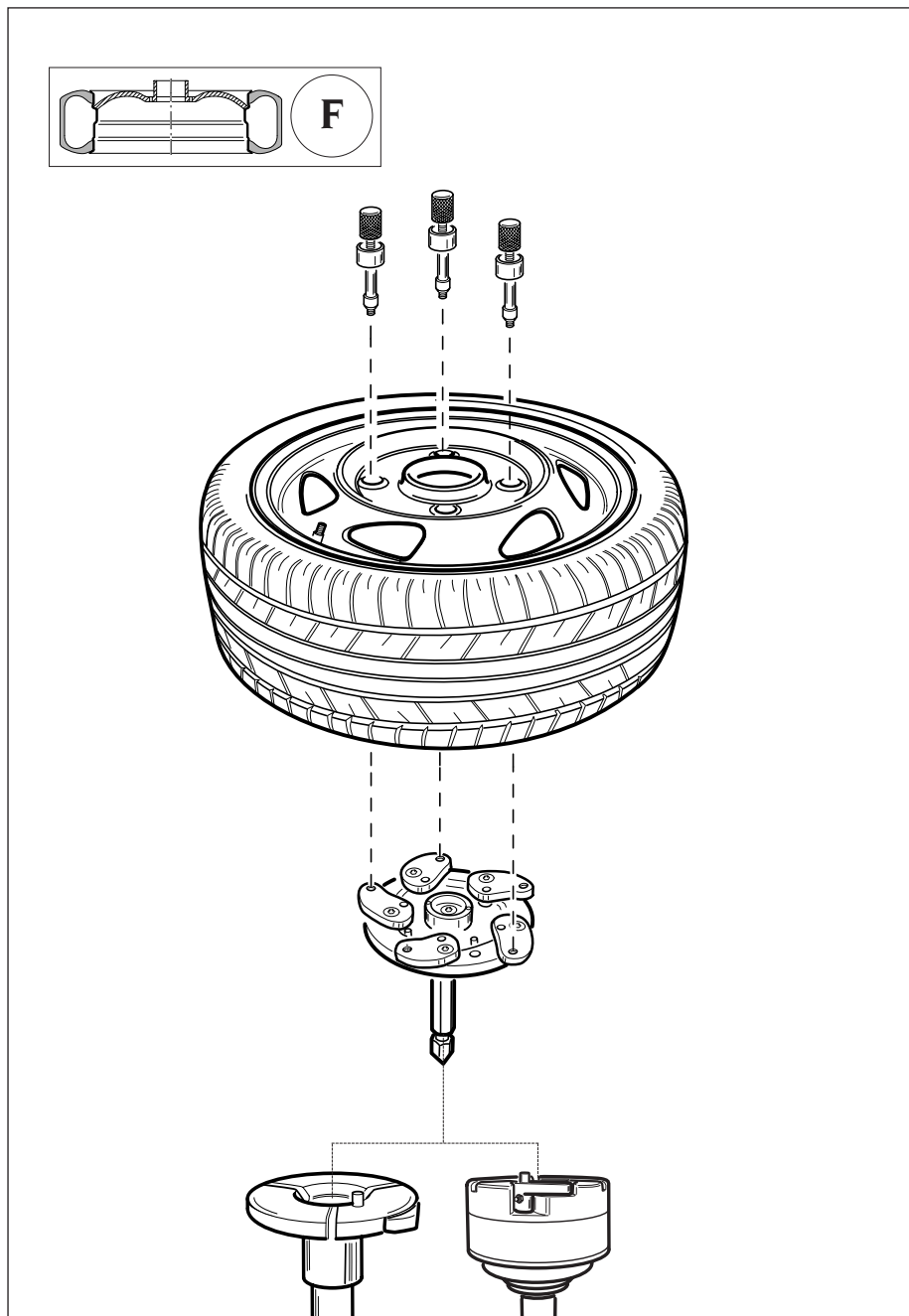

EN

WIRING DIAGRAM

AP2	Power supply unit and controls board
AP3	Display board
EV1	Solenoid valve
FU1	T 5A (on TC1 transformer)
FU2	T 5A fuse (on TC1 transformer)
FU3	T 10A fuse (on TC1 transformer)
FU4	T 10A fuse (on TC1 transformer)
FU5	T 25A fuse (on TC1 transformer)
FU6	T 2A fuse (on TC1 transformer)
FU7	T 2A fuse (on TC1 transformer)
FU8	5x20 H T 3.15A fuse (on AP2)
FU9	5x20 H T 1A fuse (on AP2)
FU10	5x20 H T 16A fuse (on AP2)
FU11	5x20 H T 16A fuse (on AP2)
HL1	Switch indicator
M1	Motor
M2	Vertical movement DC motor
M4	Linear actuator + encoder
QS1	Two-pole switch
SB4	Demounting selector
SQ5	Speed microswitch I (CLOCKWISE)
SQ6	Speed microswitch II (CLOCKWISE)
SQ7	Speed microswitch I (ANTICLOCKWISE)
SQ10	Horizontal movement reset microswitch
SQ11	Vertical movement upper limit microswitch
SQ12	Vertical movement lower limit microswitch
SQ18	Lifter microswitches
SQ19	Tool head joystick
TC1	Power supply transformer
VC1	Diode jumper
XS1	Power supply plug
XT1	Terminal board
YA1	Vertical movement DC motor brake
Z2	Vertical movement motor noise disturbance filter

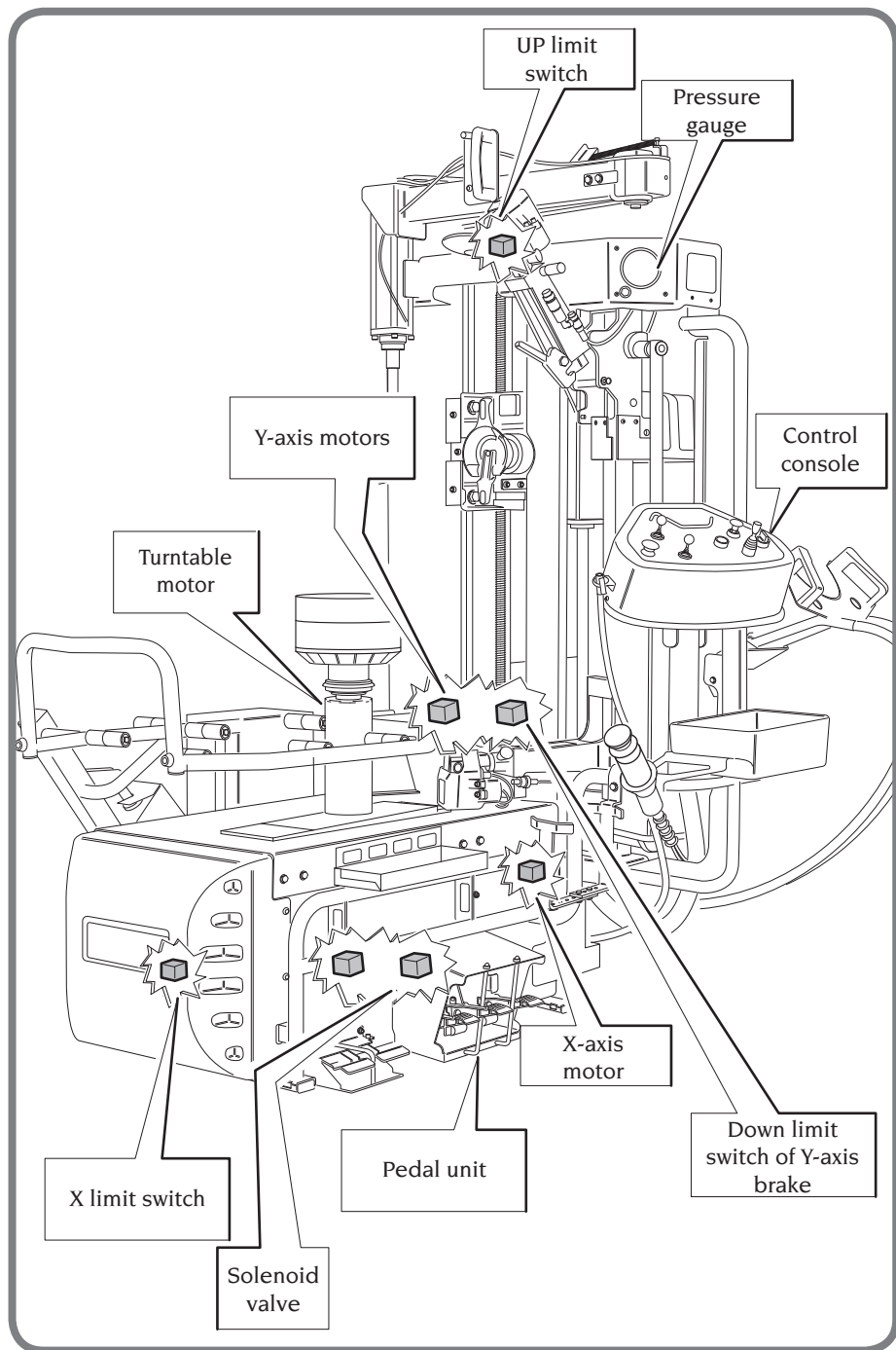

EN

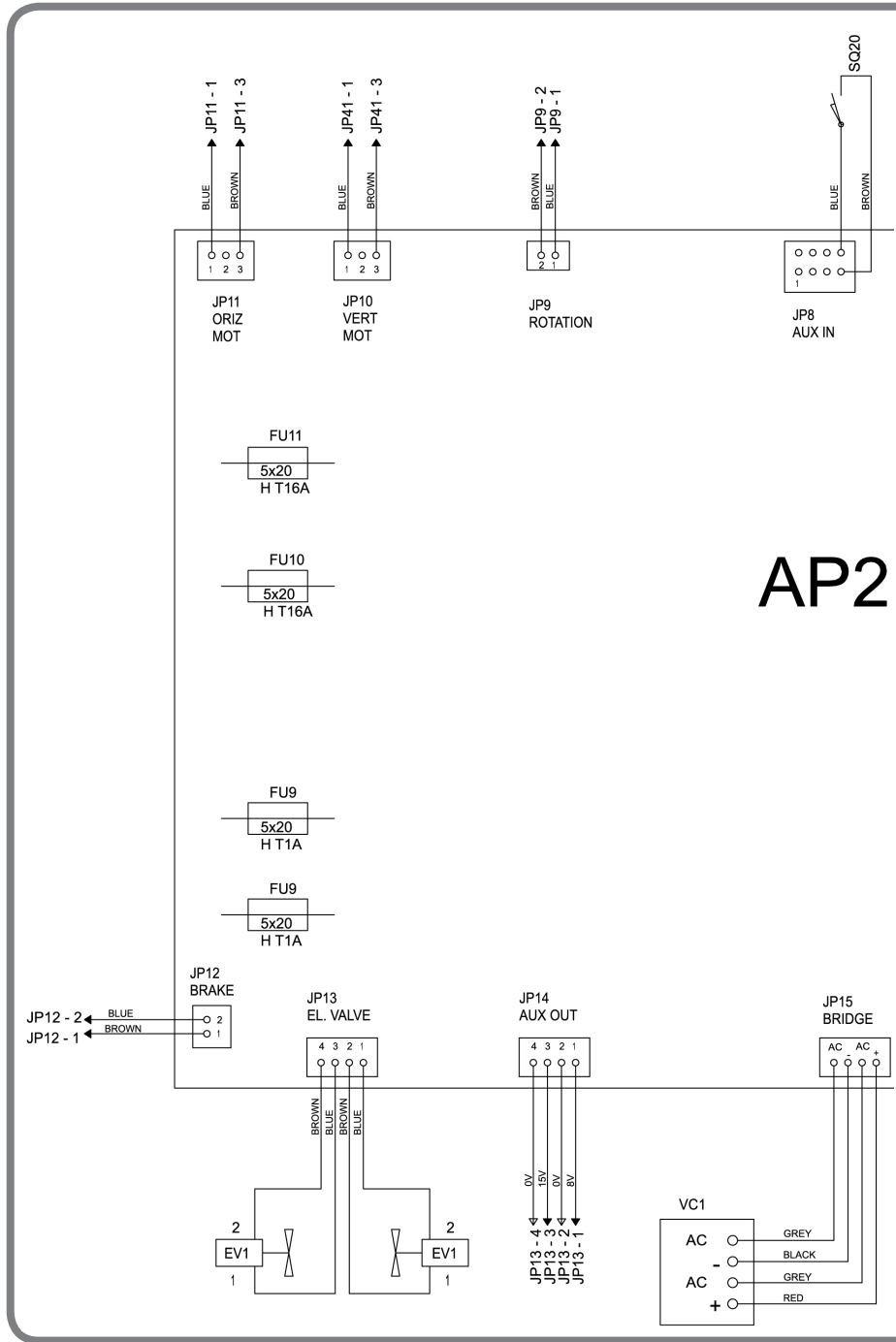

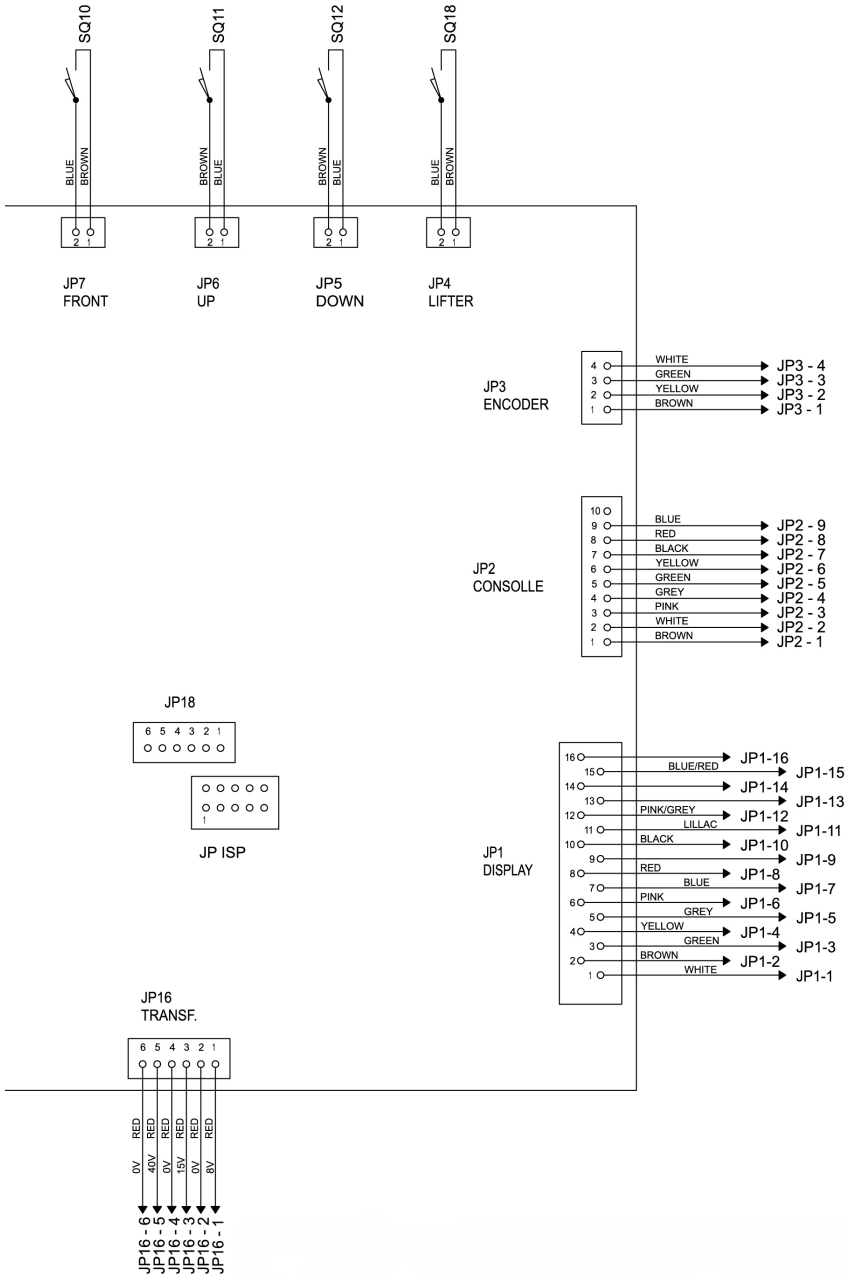

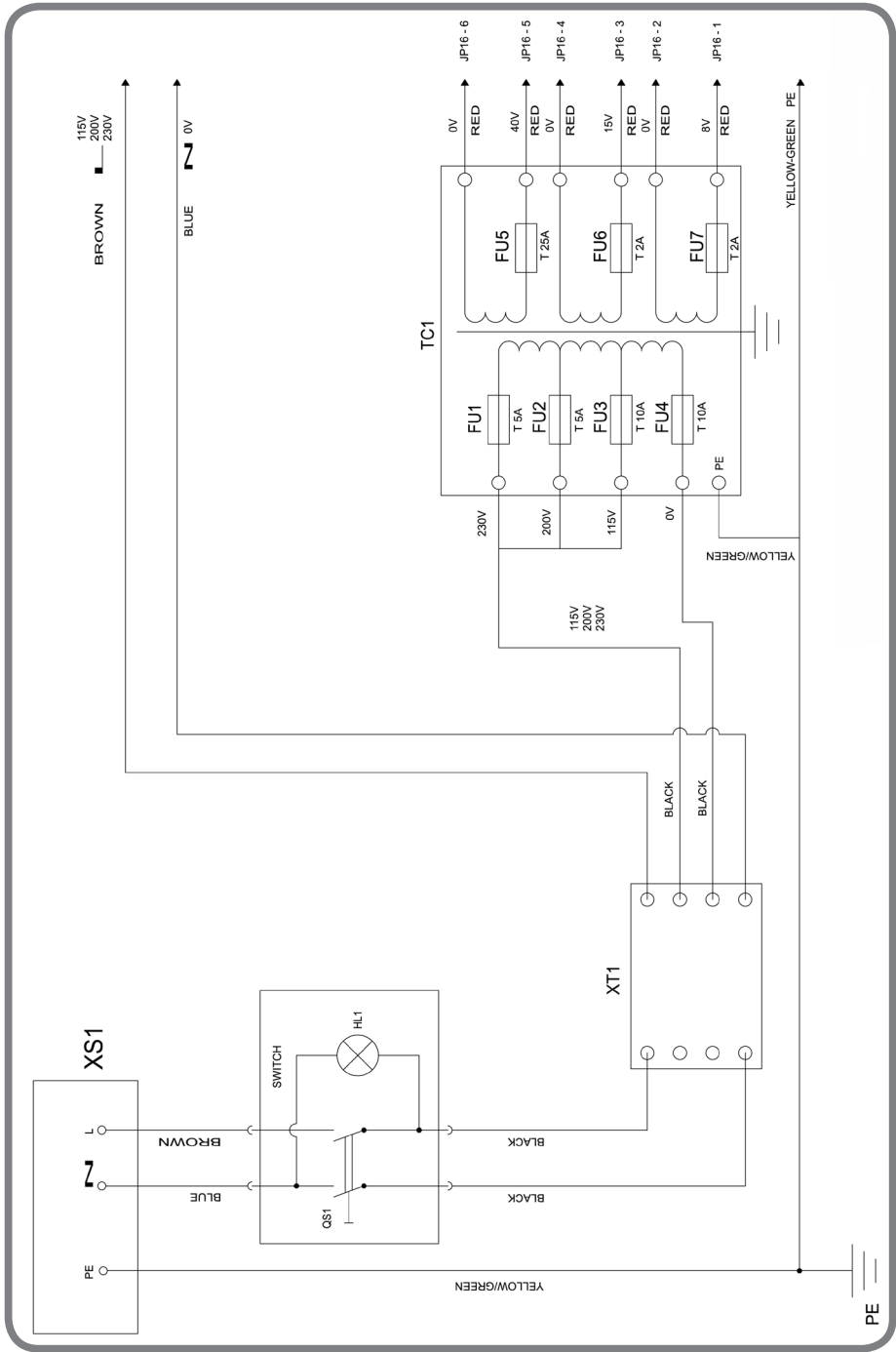

MOTOINVERTER

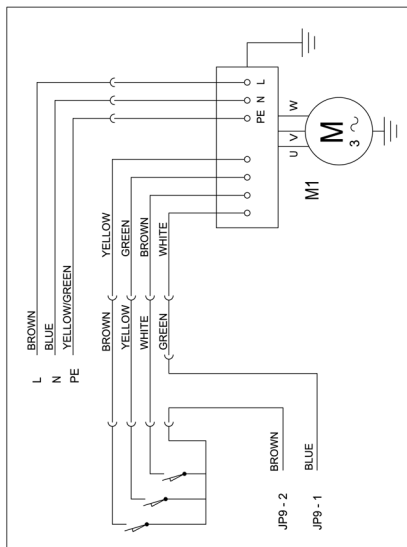

AXIS Y - VERTICAL MOVEMENT

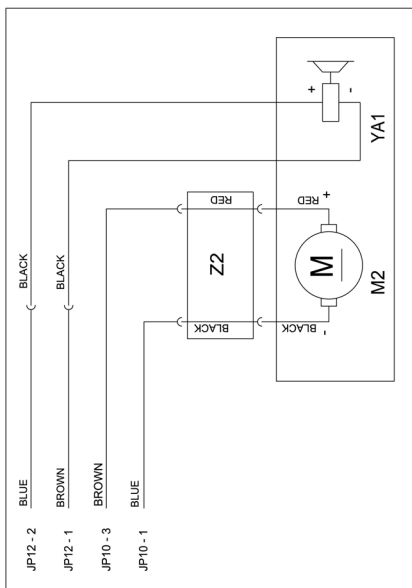

AXIS X - HORIZONTAL MOVEMENT

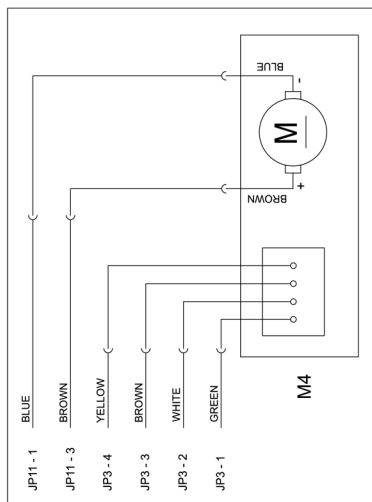

CONTROLS PANNEL

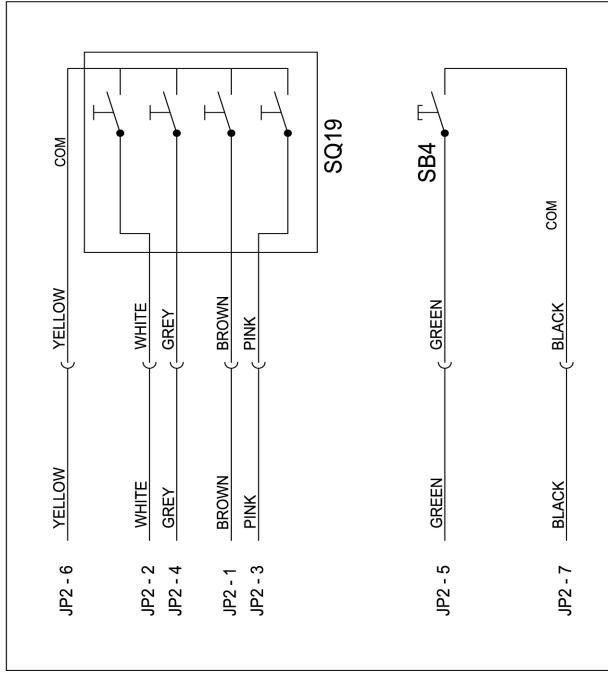

DISPALY

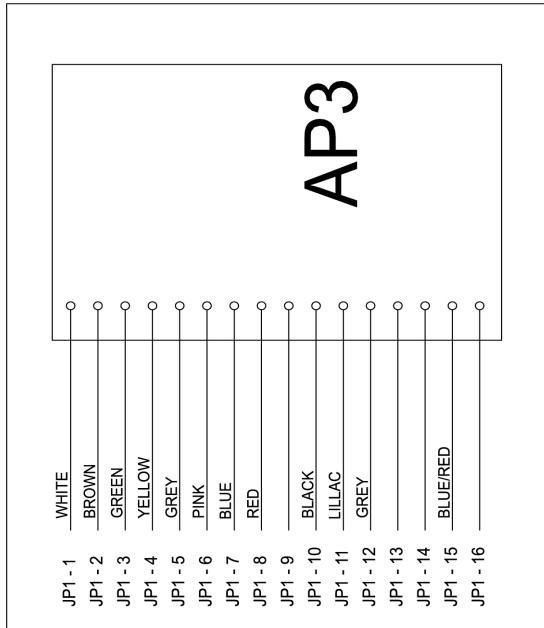

PNEUMATIC DIAGRAM

General pneumatic system diagram

Table No. 4-137990

A - DISC PENETRATION CONTROL

- 12 3/2 NC Valve
- 13 Upper locking plate cylinder
- 14 Lower locking plate cylinder
- 15 Silencer filter
- 26 Unloading regulator

B - UPPER BEAD BREAKER CONTROL

- 15 Silencer filter
- 16 5/3 NC Valve
- 17 Upper bead breaker cylinder

C - LOWER BEAD BREAKER CONTROL

- 15 Silencer filter
- 16 5/3 NC Valve
- 18 Lower bead breaker cylinder

D - TOOL HEAD MOVEMENT

- 19 3/2 NO valve
- 20 3/2 NC Valve
- 21 Tool head actuator cylinder

E - TOOL HEAD ROTATION

- 22 Valve 5/2
- 23 Tool rotation cylinder

F - HEAD HORIZONTAL MOVEMENT CONTROL

- 15 Silencer filter
- 24 5/3 NC solenoid valve
- 25 Head horizontal movement cylinder

G - LIFTER (optional)

- 16 5/3 NC Valve
- 26 Lifter valve cylinders

H - PEDAL UNIT

- 6 3/2 NC Valve
- 7 3/2 NC Valve ("AUTOMATIC" version only)
- 8 Quick discharge valve ("AUTOMATIC" version only)
- 9 Turntable cylinder ("AUTOMATIC" version only)

I - INFLATION

L - MANUAL DEFLATION

- 10 Pressure gauge
- 11 2/2 NC manual deflation valve

M - BEAD PRESSING TOOL

- 15 Silencer filter
- 16 5/3 NC Valve
- 17 Bead pressing tool cylinder



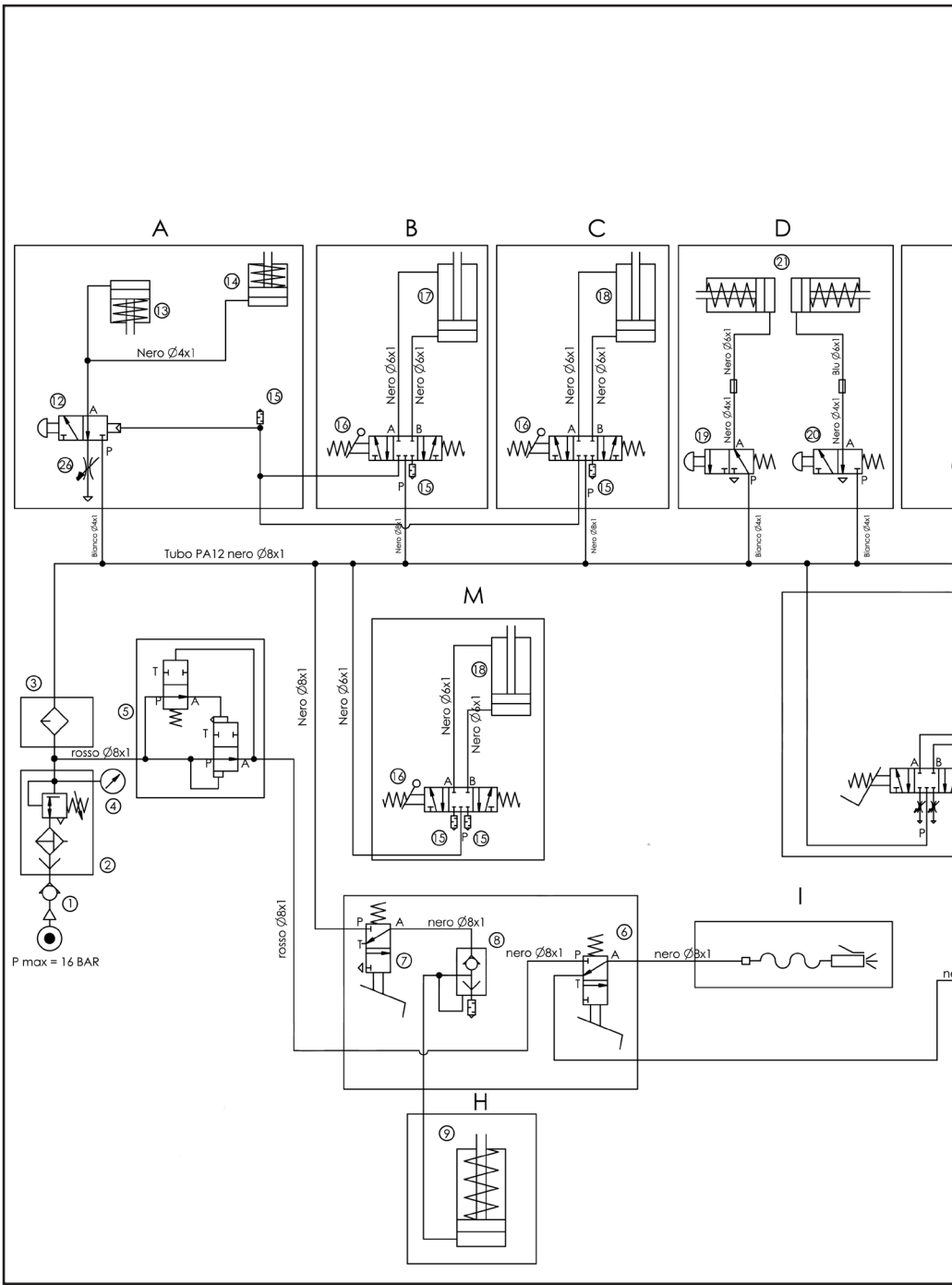

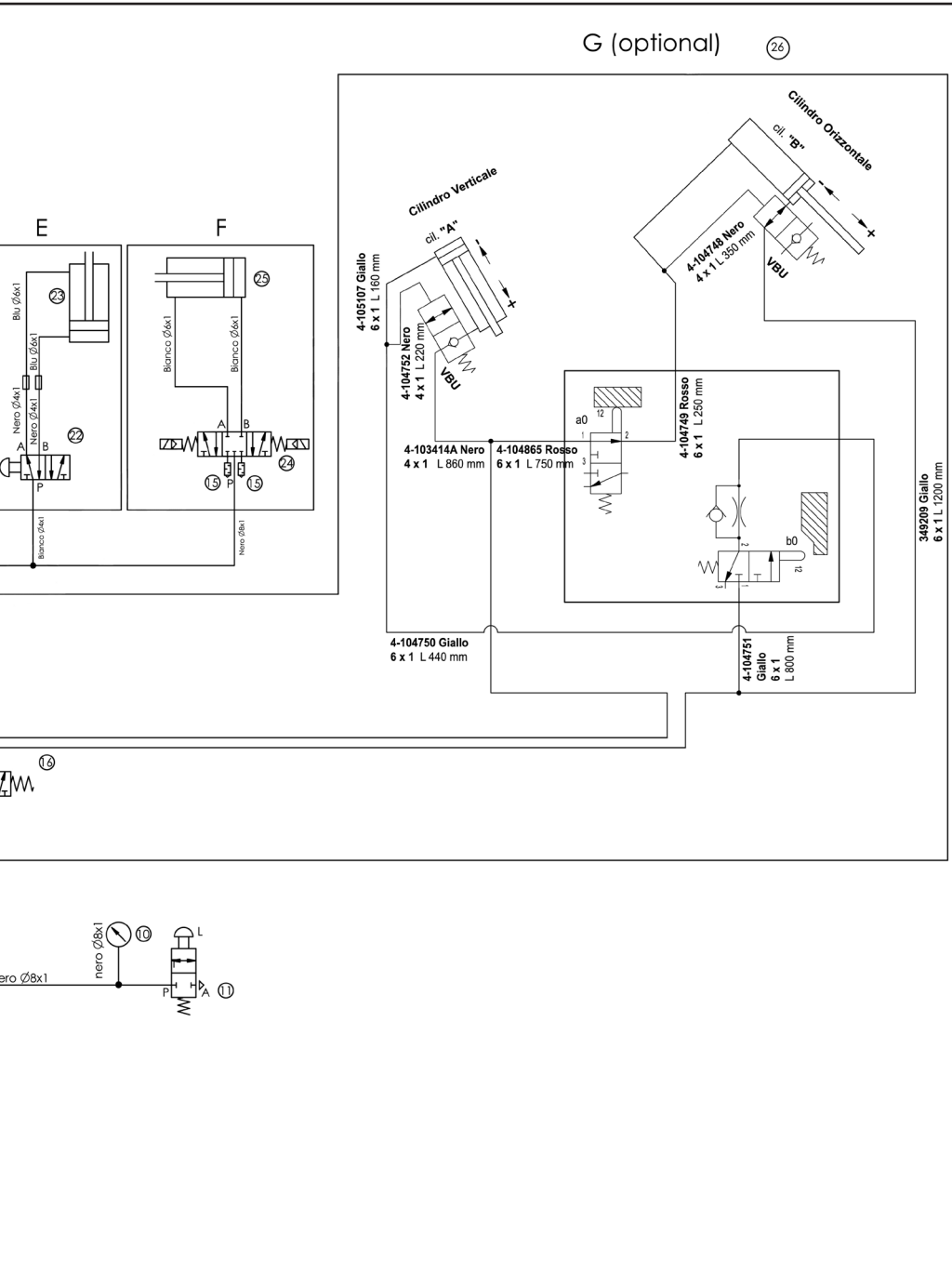

EN

IT - Dichiarazione CE di conformità - Dichiarazione di conformità UE *
EN - EC Declaration of conformity - EU Declaration of conformity *
FR - Déclaration EC de conformité - Déclaration UE de conformité *
DE - EG – Konformitätserklärung - EU – Konformitätserklärung *
ES - Declaración EC de conformidad - Declaración UE de conformidad *



COMIM - Cod. 4-137578 - 09/2019



- Ita** Quale fabbricante dichiara che il prodotto: **ARTIGLIO MASTER 28**
al quale questa dichiarazione si riferisce e di cui abbiamo costituito e deteniamo il relativo fascicolo tecnico è conforme alle sopracitate normative e Direttive.
* valido solo per macchine marcate CE
- Eng** As producer declare that the product: **ARTIGLIO MASTER 28**
to which this statement refers, manufactured by us and for which we hold the relative technical dossier, is compliant with the standards and Directives mentioned above.
* valid only for EC marked machines
- Fra** Déclarons que le materiel: **ARTIGLIO MASTER 28**
objet de cette déclaration, dont nous avons élaboré le livret technique, restant en notre possession, est conforme aux normes et Directives susmentionnées.
* valable uniquement pour le machines avec marquage CE
- Deu** Erklärt hiermit dass das product: **ARTIGLIO MASTER 28**
Worauf sich die vorliegende Erklärung bezieht und dessen technische Akte diese Firma entwickelt hat und innehält, den Anforderungen der oben erwähnten Normen und Richtlinien entspricht.
* Gilt nur für EG-gekennzeichnete Maschinen
- Spa** Declara que el producto: **ARTIGLIO MASTER28**
al cual se refiere la presente declaración y del que hemos redactado y poseemos el correspondiente expediente técnico, se conforma a las siguientes normas y Directivas:
* Valido sólo para máquinas con marcado CE