

**TT-0**

**CORGHI**  
Made in Italy



 Sollevatore ruota automatico autobilanciato per ruote da autovettura, trasporto leggero e motocicli

 *Automatic self-balancing wheel lifter for passenger car, light transport vehicle and motorcycle wheels*

 Automatischer selbstbalancierender Radheber für Räder von Autos, leichten Transportfahrzeugen und Motorrädern

 **CORGHI**  
seguì Corghi - follow Corghi



**Autobilanciato:** dotato di uno speciale sistema pneumatico che annulla completamente il peso della ruota consentendo di sollevare e centrare, senza alcuno sforzo, ruote fino a 80kg di peso

**Automatico:** la fase di scarico della ruota dall'equilibratrice è completamente automatica senza alcuna regolazione manuale dell'operatore

**Veloce:** i movimenti sono molto più rapidi di un sollevatore tradizionale a comando manuale

**Ergonomico:** comandi e supporti accessori studiati per essere nella posizione ottimale di lavoro

**Centraggio ottimale:** lo speciale sistema di autobilanciamento permette un centraggio più preciso eliminando i disallineamenti causati dal peso della ruota durante la fase di bloccaggio

#### DATI TECNICI

Portata	80 kg / 176 lbs
Pressione di alimentazione	10 bar
Pressione di lavoro	8 bar
Peso netto	60 kg



**Self-balancing:** the lifter features a special pneumatic system which completely eliminates the weight of the wheel, for effortlessly lifting and centring wheels weighing up to 80 Kg.

**Automatic:** wheels are unloaded from wheel balancer completely automatically with no manual adjustment required from the operator.

**Fast:** much faster operation than a conventional manually controlled lifter

**Ergonomic:** the controls and accessory mounts are designed to be in the ideal position for use

**Optimised centring:** the special self-balancing system ensures that the wheel is centred more precisely, eliminating clamping misalignment caused by the weight of the wheel

#### TECHNICAL SPECIFICATIONS

Load capacity	80 kg / 176 lbs
Compressed air supply pressure	10 bar
Operating pressure	8 bar
Net weight	60 kg



**Selbstbalancierend:** Er verfügt über ein spezielles Druckluftsystem, mit dem das Gewicht des Rades vollständig aufgehoben wird, wodurch bis 80 kg schwere Räder absolut mühelos angehoben und zentriert werden können.

**Automatisch:** Die Phase des Abladens des Rads von der Auswuchtmaschine erfolgt völlig automatisch, ohne jegliche manuelle Einstellung des Bedieners.

**Schell:** Die Bewegungen sind sehr viel schneller als bei einem herkömmlichen Radheber mit Handsteuerung

**Ergonomisch:** Steuerungen und Zubehörträger sind so ausgelegt, dass sie sich in optimaler Arbeitsposition befinden

**Optimale Zentrierung:** Das spezielle System der Selbstausgleichung ermöglicht eine genauere Zentrierung und beseitigt die durch das Gewicht des Rads während des Einspannens verursachten Fehlansrichtungen

#### TECHNISCHE DATEN

Tragfähigkeit	80 kg / 176 lbs
Versorgungsdruck	10 bar
Arbeitsdruck	8 bar
Nettogewicht	60 kg

## DIMENSIONI DI INGOMBRO OVERALL DIMENSIONS ABMESSUNGEN

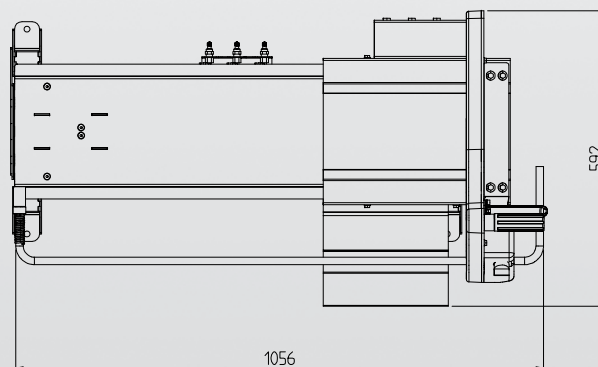
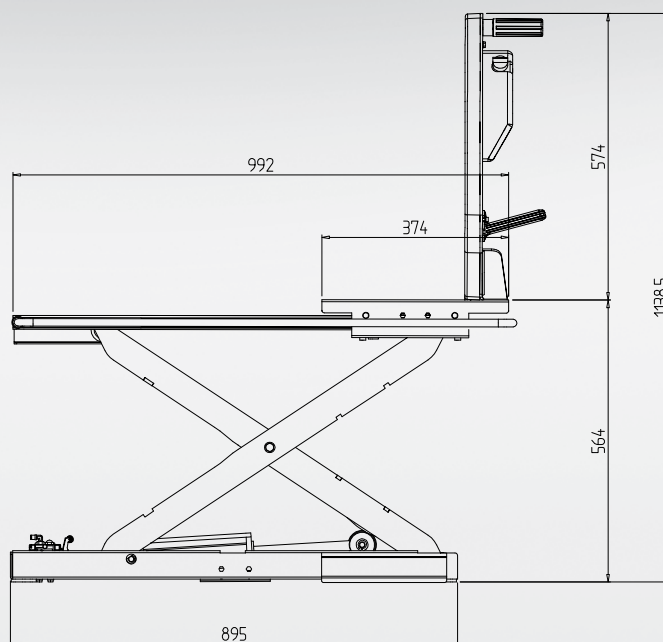

<http://www.facebook.com/CORGHISpa>



<https://twitter.com/corghispa>



<http://www.youtube.com/CORGHISpa>



Fotografie, caratteristiche ed i dati tecnici non sono vincolanti, possono subire modifiche senza preavviso. The manufacturer reserves the right to modify the features of its products at any time. Les photographes, les descriptions et les données techniques ne sont pas contraignantes. Le fabricant se réserve le droit d'apporter des modifications sans préavis. Die Fotografien, die angegebenen Eigenschaften und die technischen Daten sind nicht verbindlich und können ohne Vorankündigung geändert werden. Fotos, charakteristika y datos técnicos no son vinculantes, pueden estar sujetos a modificaciones sin previo aviso. As fotografias, as características e os dados técnicos não são vinculantes, podem ser modificados sem prévio aviso. Code: DP66000457 09/2012.

Per aiutare il pianeta ottimizzando il consumo di carta, i nostri cataloghi sono consultabili sul sito [www.corghi.com](http://www.corghi.com). Una stampa responsabile aiuta a preservare l'ambiente. To protect the planet and reduce paper usage, our catalogues are viewable online at the website [www.corghi.com](http://www.corghi.com). Printing responsibly contributes to saving the environment.



CORGHI S.p.A. a NEXION GROUP COMPANY - Strada Statale 468 n° 9 - 42015 CORREGGIO - R.E. - ITALY  
Tel. ++39 0522 639.111 - Fax ++39 0522 639.150 - [www.corghi.com](http://www.corghi.com) - [info@corghi.com](mailto:info@corghi.com)